

Subject: Installation of a tailwheel instead of the plastic foam tailskid.

Affected gliders: Optional for all ASW 19 and ASW 19 B.

Compliance: None.

Reason: For frequent operation from hard surface runways a tailwheel is more comfortable than a plastic foam tailskid with its wear plate.

Action: 1. Make the parts:

	<u>Factory Standard-No.</u>
1 Radkasten (wheel housing)	99.010.5470
2 Beschlage f. Spornrad (tailwheel fittings)	99.000.0987
2 Bundbuschen (bushings)	99.323.0025
1 Distanzrohr (spacer tube)	99.101.0668
+ 1 Rad 210 x 65, komplett (wheel 210 x 65 complete)	

and glue them into the fuselage tail area according to drawings 200.29.1001 and 200.29.S1, sheets 1 - 4.

The FRP-laminate ① = 3 layers 92140 ✕ must be put around the wheel housing.

Now the edge has to be faired by means of Conticell-foam and microballoon filler (100 parts in weight of Epikote 162, 30 parts in weight of Epikure 113 and max. 25 parts in weight of microballoons).

The surface is covered with laminate ④ = 1 layer 92110 (see drawing 200.29.S 1, sheets 1 and 3).

All external surfaces are filled with light-weight Polyester filler and then painted with Polyester gelcoat no.03-69 #69 mixed with 3% hardener 07-20 500; subsequently they are sanded.

2. In the Flight and Operations Manual the page 26 (ASW 19) respectively the page 26 (ASW 19B) must be exchanged against the corrected pages with the same number which explain the tailwheel and its tire pressure by the following supplement: ** If a tailwheel of size 210 x 65

is installed, its tire pressure must be 2,3 to 2,5 bar (33 to 35,5 p.s.i.). These pages are marked with the correction note "TM Nr.15".

Weight & balance:

After the installation of the tailwheel the weight of the fuselage is increased by about 1,5 kg (~ 3 lbs) and the empty weight C.G. is moved backwards by approx. 25 mm (1 inch). So after the installation of the tailwheel a weight and balance procedure must be carried out.

Notes:

1. Prior to the installation it has to be checked whether the additional weight does not unacceptably reduce the payload and/or the C.G. limits.
2. Original parts as well as the corrected pages 26 (ASW 19) respectively 26 (ASW 19 B) are available from Schleicher.

Drawings:

For this Technical Note no.15 the following drawings are new made:

200.29.S 1, sheets 1 - 4
200.29.1001
200.29.0003
200.29.0004
200.29.0005
200.29.0151

Poppenhausen, August, 3, 1983

ALEXANDER SCHLEICHER
Segelflugzeugbau

Gerhard Waibel.

This Technical Note has been approved by the LBA under the date of Aug. 19, 1983, and has been signed by Mr. Schmaljohann.

The translation into English of this Technical Note no.15 has been done by best knowledge and judgement. In any case of doubt the German original is authoritative.

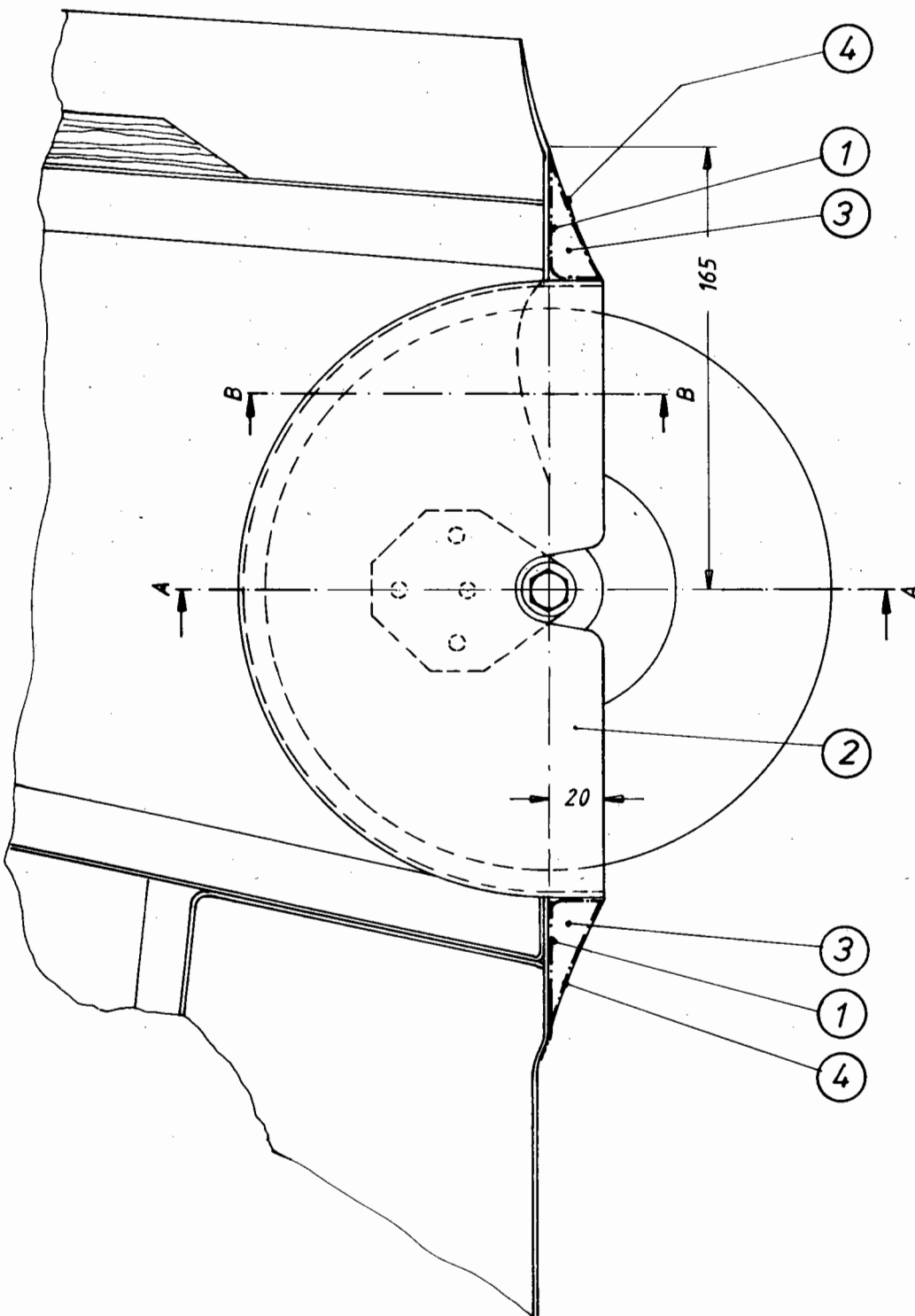

				Datum	Name	Typ	Benennung	Maßst.
				Bearb. 29.11.82	Juw	ASW 19 20	Spornrad- Einbau	1:2,5
				Geprü.				
				Norm				
				A. Schleicher Segelflugzeugbau 6416 Poppenhausen		Zeichnungsnummer L-308/314 200.29.S1		Blatt 1 4 Bl.
Zust.	Änderung	Datum	Na.	Urspr.	Ers. f.	Ers. d.		

Sheet 4

No. of sheets: 11

ASW 19 and ASW 19 B
 Technical Note
 No.15

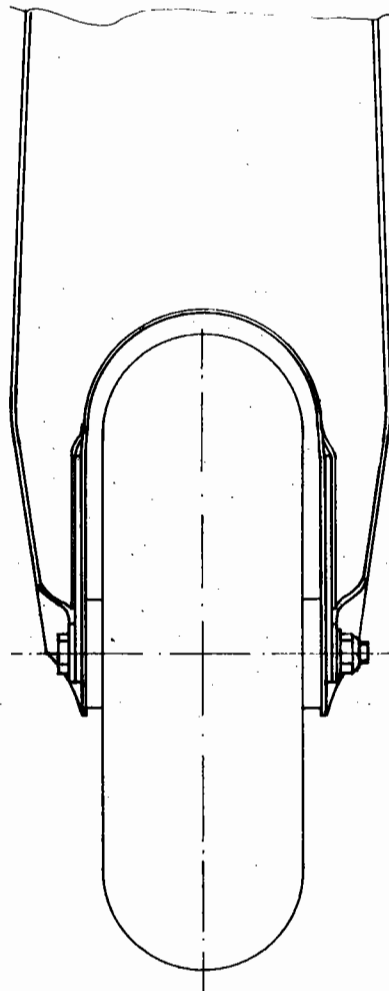

				Datum	Name	Typ	Benennung	Maßst.
				Bearb. 29.11.82	Juw	ASW 19 20	Spornrad-Einbau Schnitt A-A	1:2,5
				Geprü				
				Norm				
				A. Schleicher Segelflugzeugbau 6416 Poppenhausen		Zeichnungsnummer L-308/314 200.29.S1		Blatt 2 4 Bl.
Zust.	Änderung	Datum	Na.	Urspr.	Ers. f.	Ers. d.		

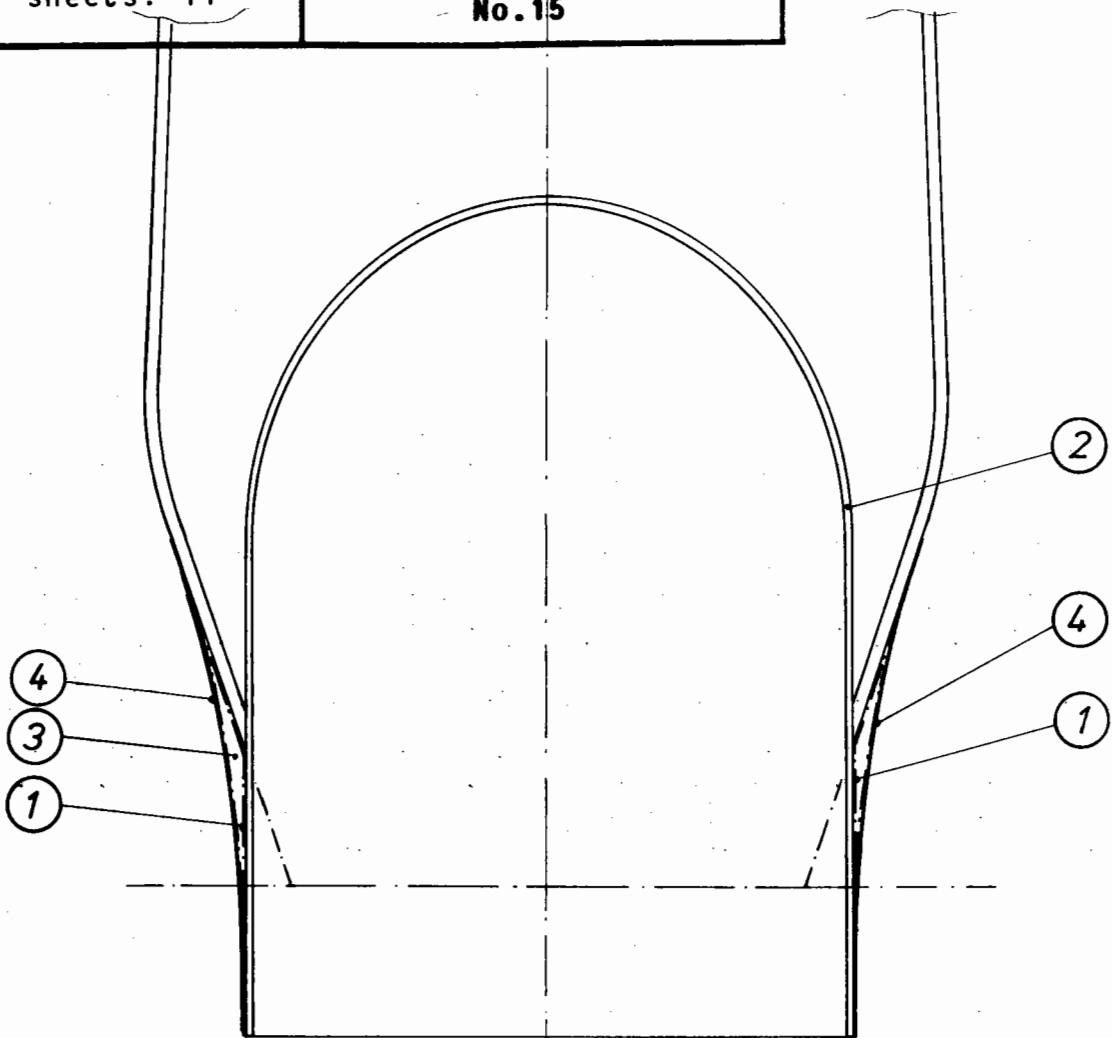

	1 Lage Glasgewebe	4	92 110			
	Microballoonspachtel und Radkasten	3	Conticell - Schaum			
	3 Logen Glasgewebe	2		93. 010. 5470		
		1	92 140			
St	Benennung	Lfd. Nr.	Werkstoff	Rohmaße Teil- oder DIN-Nr.	Bemerkung	
		Datum	Name	Typ	Benennung	Maßst.
		Bearb. 29.11.82	Juw	ASW 19 20	Spornrad - Einbau Schnitt B - B	1:1
		Geprü.				
		Norm				
		A. Schleicher Segelflugzeugbau 6416 Poppenhausen		Zeichnungsnummer L-308/314	Blatt 3	
				200.29.S1	4 Bl.	
Zust.	Änderung	Datum	Na.	Urspr.	Ers. f.	Ers. d.

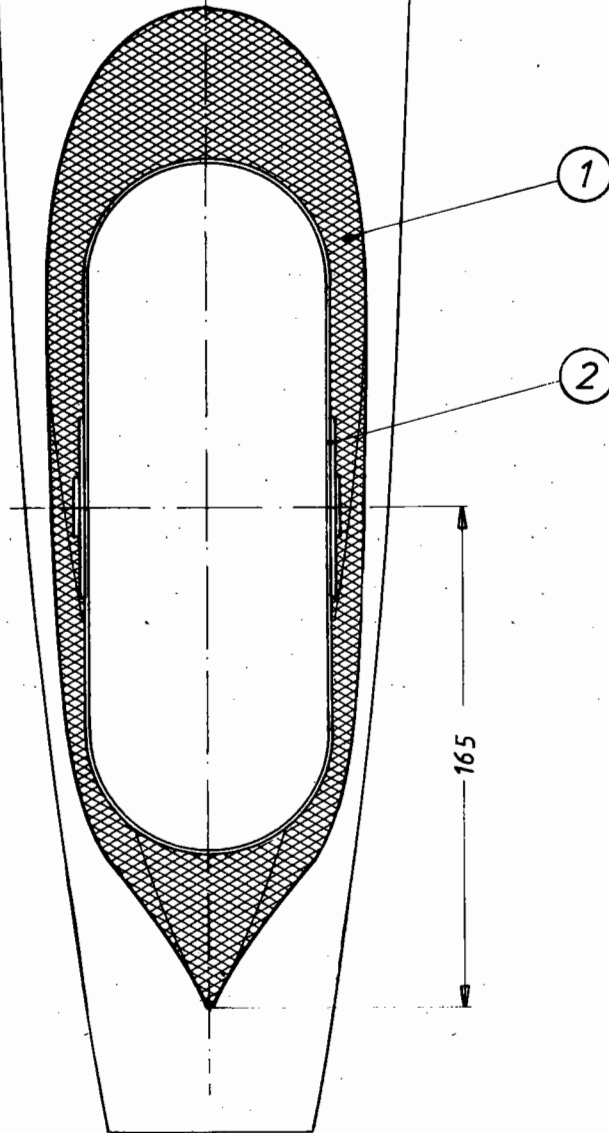

	<i>Radkasten</i>	2		99.010.5470		
	<i>3Lagen Glasgewebe</i>	1	92 140			
St.	Benennung	Lfd. Nr.	Werkstoff	Rohmaße Teil- oder DIN-Nr.	Bemerkung	
		Datum	Name	Typ	Benennung	Maßst.
		Bearb. 29.11.82	Juw	ASW 19 20	Spornrad-Einbau Ansicht von unten	1:25
		Geprü.				
		Norm				
		A. Schleicher Segelflugzeugbau 6416 Poppenhausen		Zeichnungsnummer L-308/314 200.29.S1	Blatt 4 4 Bl.	
Zust.	Änderung	Datum	Na.	Urspr.	Ers. f.	Ers. d.

Sheet 7

No. of sheets: 11

ASW 19 and ASW 19 B
Technical Note
No. 15

Typ	Gleiches Teil wie:	Stück
190	29.1001	1
200	29.1001	1
210	29.1003	1
220	29.1001	1

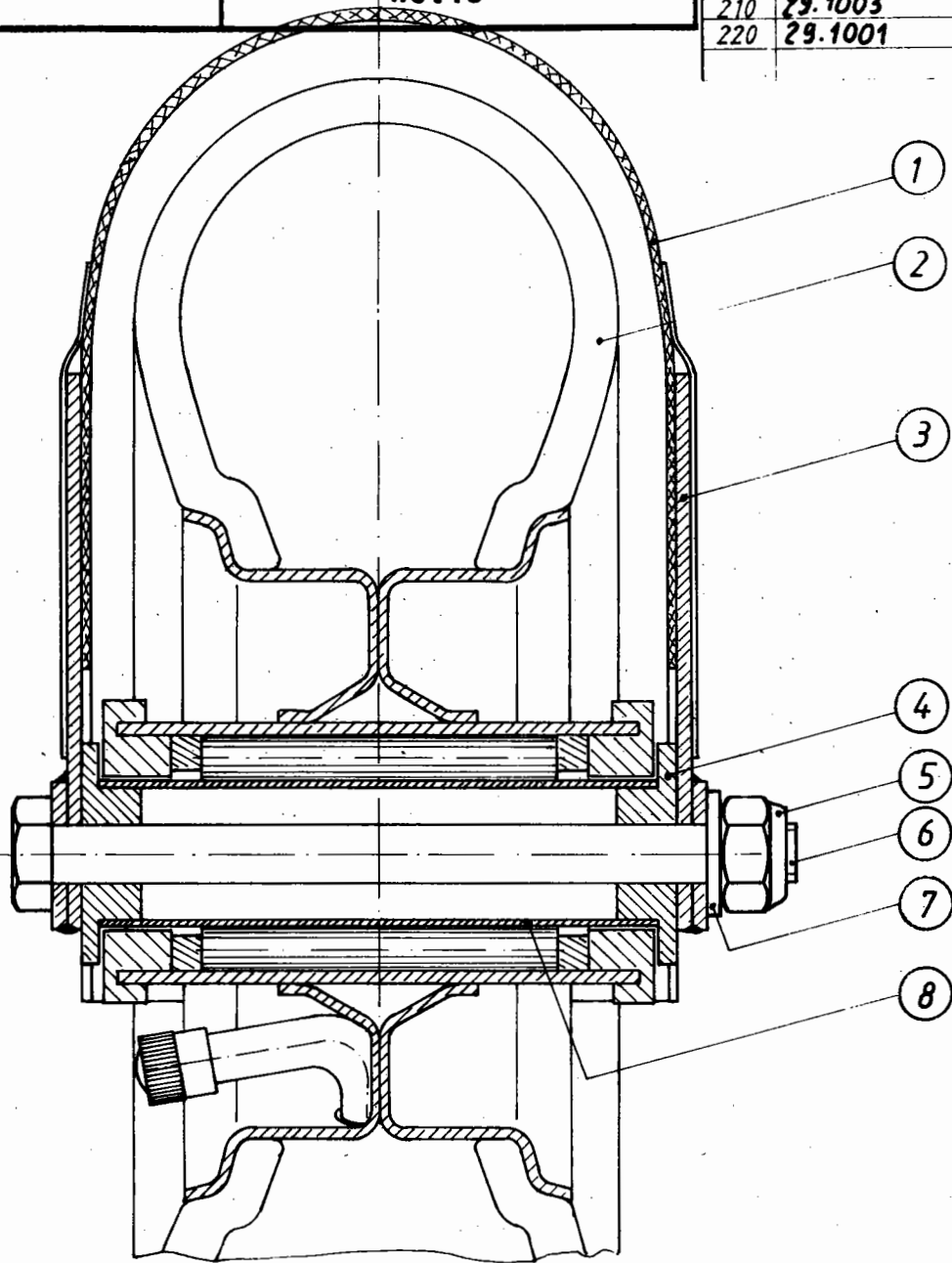

1	Distanzrohr	8		99.101.0668	
1	Scheibe $\phi 8,4$	7		DIN 125-St	
1	Sechskantschraube M8 x 110	6		DIN 931-8.8 B3E	gekürzt auf 100
1	Sicherungsmutter NM8	5		DIN 980-6	
2	Bundbuchse	4		99.323.0025	
2	Beschlag f. Spornrad	3		99.000.987	
1	Rad 210 x 65, kompl.	2			
1	Radkasten	1		99.010.5470	

St.	Benennung	Lfd. Nr.	Werkstoff	Rohmaße Teil- oder DIN-Nr	Bemerkung		
			Datum	Name	Typ	Benennung	Maßst.
			Bearb.	Juw		Spornrad, kompl.	1:1
			Geprü.		ASW 19		
			Norm		20		
			A. Schleicher		Zeichnungsnummer	L-308/314	Blatt
			Segelflugzeugbau		200.29.1001	99.000.7421	Bl.
			6416 Poppenhausen				
Zust.	Änderung	Datum	Na.	Urspr.	Ers. f.	Ers. d.	

Sheet 8

No. of sheets: 11

ASW 19 and ASW 19 B
Technical Note
No.15

Typ	Gleiches Teil wie:	Stück
190	29.0006	2
200	29.0003	2
210	29.0003	2
220	29.0018	2

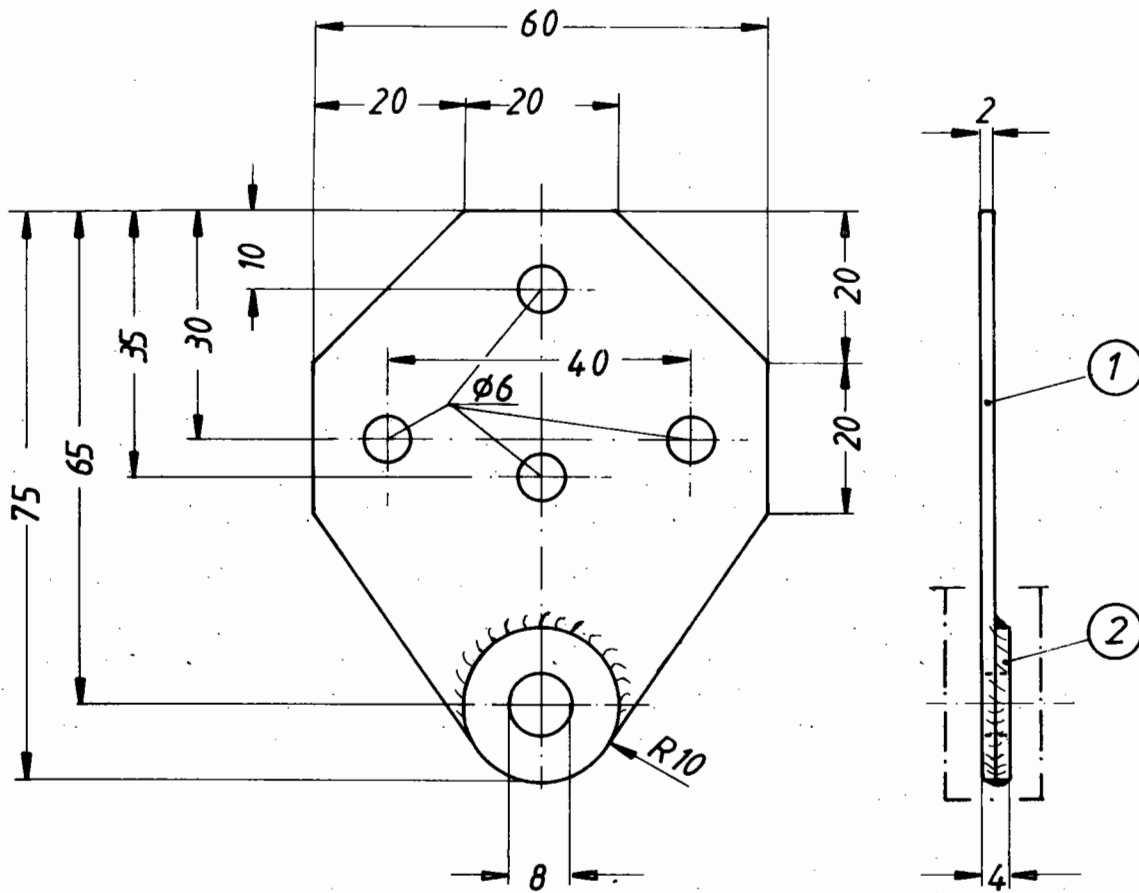

Ob.: sandgestrahlt (--- lackiert)

2	Scheibe $\phi 8/20 - 2$ (Stanzteil)	2	1.7214.4/1.7734.4	99.402.0007			
2	Blech	1	1.7214.4/ 1.7734.4	2 x 60 x 75			
St.	Benennung	Lfd. Nr.	Werkstoff	Rohmaße Teil- oder DIN-Nr.	Bemerkung		
			Datum	Name	Typ	Benennung	Maßst.
			Bearb.	Juw	ASW 19 20	Beschlag für Spornrad	1:1
			Geprü.				
			Norm				
			A. Schleicher Segelflugzeugbau 6416 Poppenhausen		Zeichnungsnummer L -308/314 200.29.0003 99.000.0987		Blatt
							Bl.
Zust.	Änderung	Datum	Na.	Urspr.	Ers. f.	Ers. d.	

Sheet 9
No. of sheets: 11

ASW 19 and ASW 19 B
Technical Note
No. 15

Typ	Gleiches Teil wie:	Stück
190	29.0004	1
200	29.0004	1
210	29.0004	1
220	29.0019	1

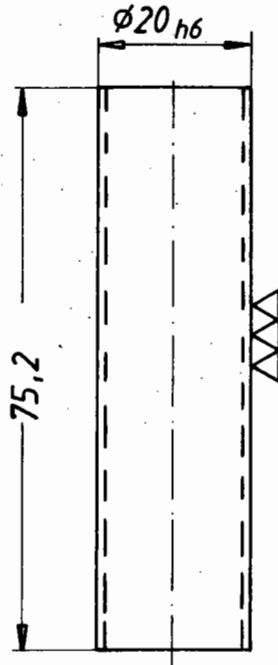

Mat.: St. 35 BK/BKW

gratfrei

1 Stück

				Datum	Name	Typ	Benennung	Maßst.
					Juw	ASW 19 20	Distanzrohr für Spornradachse	1:1
				A. Schleicher Segelflugzeugbau 6416 Poppenhausen		Zeichnungsnummer	L-308/314 99.101.0668	Blatt Bl.
Zust.	Änderung	Datum	Na.	Urspr.	Ers. f.	Ers. d.		

Sheet 10

No. of sheets: 11

**ASW 19 and ASW 19 B
Technical Note
No.15**

Typ	Gleiches Teil wie:	Stück
190	29.0005	2
200	29.0005	2
210	29.0005	2
220	29.0017	2

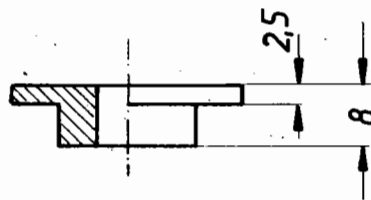
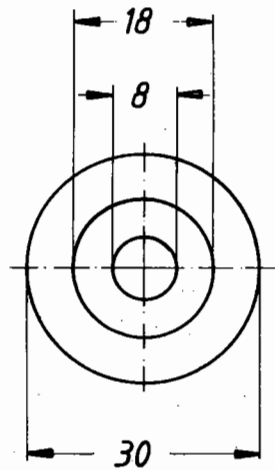

Mat.: 2.0380. /2.0420.

gratfrei

2 Stück

				Datum	Name	Typ	Benennung	Maßst.
				Bearb.	Juw	ASW 19 20	Bundbuchse für Spornradachse	1:1
				Geprü.				
				Norm				
A. Schleicher Segelflugzeugbau 6416 Poppenhausen						Zeichnungsnummer L-308/314		Blatt
						200.29.0005 99.323.0025		Bl.
Zust.	Änderung	Datum	Na.	Urspr.	Ers. f.		Ers. d.	

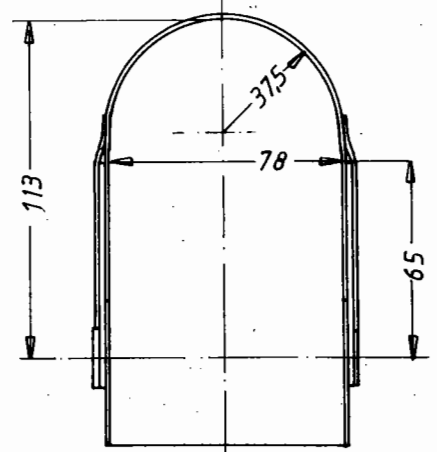
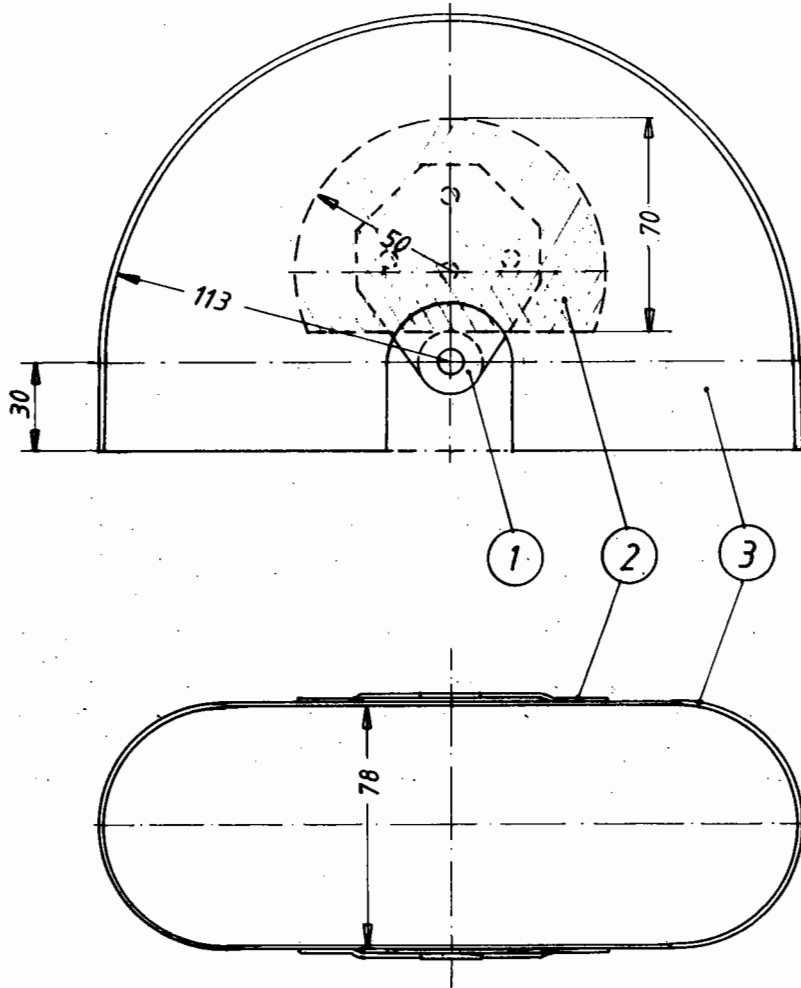

Typ	Gleiches Teil wie:	Stück
190	29.0151	1
200	29.0151	1
210	29.0151	1
220	29.0153	1

1	Radkasten	3	3 Lagen 92 140			
2	Verstärkung	2	2 Lagen 92 140			
2	Beschlag für Spornrad	1		99.000.0987		
St.	Benennung	Lfd. Nr.	Werkstoff	Rohmaße Teil- oder DIN-Nr.	Bemerkung	
		Datum	Name	Typ	Benennung	
		Bearb.	Juw	ASW 19 20	Radkasten	
		Geprü.				1:2,5
		Norm				
		A. Schleicher Segelflugzeugbau 6416 Poppenhausen		Zeichnungsnummer L-308/314 200.29.0151	Blatt BI	
Zust.	Änderung	Datum	Na.	Urspr.	Ers. f.	
					Ers. d.	