

<u>Glider types:</u>	ASW 22, ASW 22 B	TN-No. 08
	ASW 22 BE	TN-No. 01
	ASH 25	TN-No. 10
	ASH 25 E	TN-No. 09

Subject: Securing of L'HOTELLIER quick-release connectors (ball and swivel joints) as per Airworthiness Directive (AD) "93-001 L'HOTELLIER" of the German Civil Aviation Authority (LBA) dated March 3, 1993.

Serial number applicability:

ASW 22, ASW 22	Data Sheet No.L-351, all serial no.s.
ASW 22 BE,	Data Sheet No.L-834, all serial no.s.
ASH 25,	Data Sheet No.L-364, all serial no.s.
ASH 25 E,	Data Sheet No.L-858, all serial no.s.

Compliance: None; optional as replacement for the safety pin (spring clip, similar to standard DIN 11 024) which until now was recommended by Schleicher. See also the AD-note 93-001.

Reason: The securing of the L'HOTELLIER quick-release connectors by means of safety pins (spring clips) has always proved to be very reliable but in the case of some SCHLEICHER glider types it has been complicated to fit them. Several proposals to improve the situation have become known to us, and the solution developed by Dipl.Ing. Klaus Wedekind has demonstrated to be easy-to-operate and relatively easy to retrofit. According to the LBA the "Wedekind safety sleeve" provides the same security as the safety pins and has been LBA-approved under the date of May 18, 1993.

Action: **L'HOTELLIER quick-release connector with thread adjusting head:**

The installation of the safety sleeve AS-V is done in accordance with the "Hints for retrofiting" of the general Technical Note "Wedekind-safety sleeve, LBA-approved under the date of May 18, 1993". However, the following additional notes must be strictly regarded:

Prior to undoing the adjusting head its adjustment length must be measured in order to avoid having to re-adjust the control surfaces or flaps after the re-fitting of the heads!

Contrary to the note to bore the blind rivets by means of a drill dia 3.5 mm we recommend instead to use a drill of dia 4.1 mm.

In order to be able to fit the bushing (2) it may be necessary to file down any excess material at the outside diameter of the adjusting head (e.g. at the seams) to exactly the rod diameter of 16 mm. Adjusting head then must again be protected from corrosion!

It may also become necessary for the blind rivet head to ream the bushing (2) slightly at the side.

If the thread of the adjusting head has been painted, it may become necessary to re-cut the thread with a screw die M10x1 in order to be able to screw the M10x1 nut (8) onto the thread of the adjusting head. After assembly the thread must be again protected from corrosion!

Further to the note given under point "Hints for retrofitting" on Sheet 3 of the "Wedekind safety sleeve" Technical Note the taping of the thread will not only serve for securing the M10x1 nut (8) but it serves as protection to prevent a fouling of the adjusting head; and this does **NOT** apply to the glider types ASW 22 and ASH 25!

**L'HOTELLIER quick-release connector rivetted into the Dural push rod:**

The installation of the safety sleeve AS-S is done in accordance with the hints for retrofitting contained in the general Technical Note "Wedekind-safety sleeve, LBA-approved under the date of May 18, 1993".

However, the following additional notes must be strictly regarded:

Contrary to the note to bore the blind rivets by means of a drill dia 3.5 mm we recommend instead to use a drill of dia 4.1 mm.

If it is very hard to pull the L'HOTELLIER quick-release connector (ball and swivel joint) off the push rod, it is recommended to use a suitable retaining tool for the push rod and for the L'HOTELLIER quick-release connector so that the Dural push rod dia. 16x1mm and the ball socket will not be damaged (e.g. use half-shells for clamping).

Measured from the flange of the L'HOTELLIER quick-release connector, the clearance up to the drill hole dia. 2mm for the spring pin (6) is 31 mm.

In order to drill the hole dia. 2 mm for the spring pin (6) into the bushing (4) and into the push rod, it is best to fix the bushing onto the push rod, e.g. by means of adhesive tape.

The L'HOTELLIER quick-release connector of the flap push rod at the wing-wing-separation point at 3.8 meters CANNOT be fitted with the "Wedekind-safety sleeve"! At this location it must be secured by means of safety pins (spring clips) only, as recommended by SCHLEICHER or other glider manufacturers. This item (AS P/N 99.000.2043) can be obtained from SCHLEICHER.

Material & drawings:

General Technical Note "Wedekind safety sleeve, LBA-approved under the date of May 18, 1993"; and in case of

L'HOTELLIER quick-release connectors with thread adjusting head:

Materials -

Designation	Part no.	Pieces
Bushing dia.20x1,8, 6 long	2	1
Compression spring I dia.17,5x0,9, 17 long	3	1
Safety sleeve AS-V	5	1
Spring pin DIN 1481 - 2x22	6	1
Washer dia.10,5/20 - 1,5	7	1
Hexagonal nut M10x1 - DIN 439	8	1
Blind rivet dia.4x6,8 - DIN 7337 A	/	4

and in case of  
L'HOTELLIER quick-release connectors riveted into pushrod:

Materials -

Designation	Part no.	Pieces
Bushing dia.20x1,8, 6 long	2	1
Compression spring I dia.17,5x0,9, 17 long	3	1
Bushing dia.20x1,8, 7 long	4	1
Safety sleeve AS-S	5	1
Spring pin DIN 1481 - 2x22	6	1
Blind rivet dia.4x6,8 - DIN 7337 A	/	4

In addition one pair of spring clips, AS P/N 99.000.2043, for the L'HOTELLIER quick-release connector of the flap push rod at the wing-wing-separation point at 3.8 meters.

The material required for this mod can be ordered from Messrs. SCHLEICHER Tel.+49-(0)6658-890 or Fax+49-(0)6658-8940. The customers must state the glider type in question and its serial number.

Current price for the parts to modify one quick-release connector is about DM 20,00.

Weight & Balance: Negligible.

Notes: The green marking of the bushing (4) which is referred to on Sheet 2 of the Technical Note "Wedekind-safety sleeve" is not required.

After the assembly of the "Wedekind safety sleeves" the control surfaces must be checked for full deflection and free movement in the area of the safety-sleeves towards root rib openings, fittings etc. Particular attention must be given to the airbrake push rod wing-wing-separation point at 3.8 meters: it must not touch the metal panel of the upper airbrake when the airbrakes are retracted !

The Action under this mod can be done by a competent person. The accomplishment of this mod must be certified by a licensed aviation inspector in the glider's inspection documents and in the log-book.

Poppenhausen, July 13, 1993

**ALEXANDER SCHLEICHER**  
GmbH & Co.

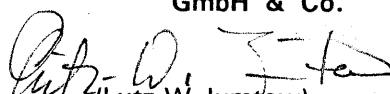
i.A.   
(Lutz-W. Juntow)

The German original of this Technical Note has been approved by the LBA under the date of Sept.6, 1993 (signature: SCHMALJOHANN). The translation into English has been done by best knowledge and judgement; in any case of doubt the German original is controlling.

Dipl.-Ing.  
Klaus Wedekind  
Am Südhang 56  
D-57548 Kirchen  
GERMANY

## WEDEKIND - SICHERUNG

Safety device for  
L'HOTELLIER ball and  
swivel connectors



Page 1 of 2

LBA signed:

11. Jody  
10. Juni 1994

Scale 2:1

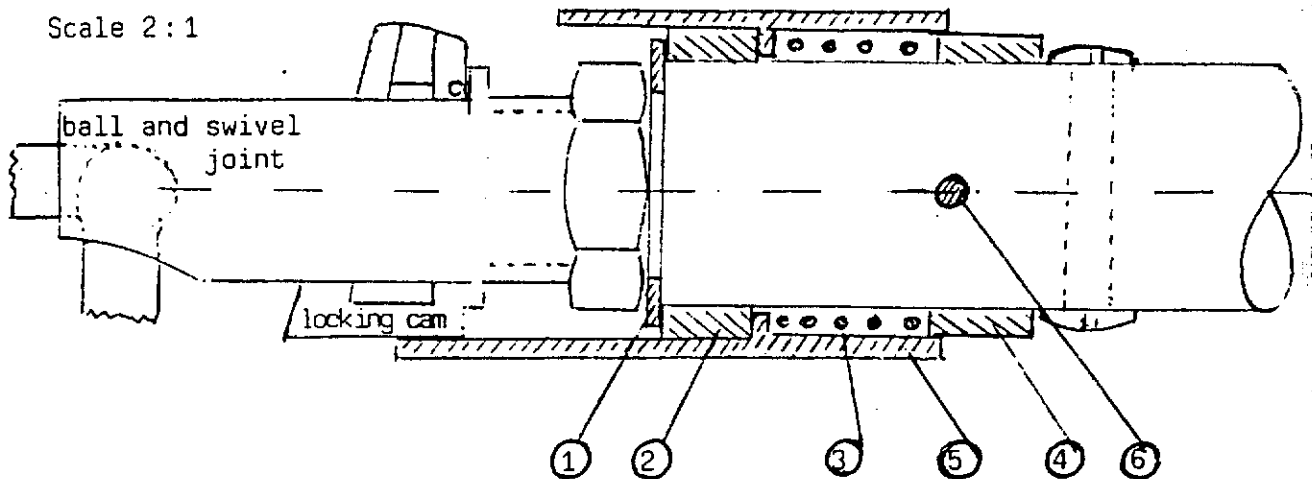

### Description

The automatic WEDEKIND safety sleeve is an alternative to the other safety devices for "L'Hotellier" ball and swivel joint connectors listed in the LBA Airworthiness Directive No. 93-001 L'HOTELLIER.

Only the coupling ball fully home in the swivel joint, the WEDEKIND safety sleeve ⑤ will slide over the lower end by the wedge-shaped locking cam and secures the latter from being released unintentionally. The safety sleeve is held in the "secured" position by a compression spring ③ with a force of 1,5 N.

The WEDEKIND safety sleeve is also a protection against improper control connections as it will not slide over the lower end of the wedge-shaped locking cam if the coupling ball is not fully home in the swivel joint.

The WEDEKIND safety sleeve may be used for all sizes of "L'Hotellier" couplings, whether straight or vertical control rod connections are concerned.

Retro-fitting of the safety sleeve must comply with the relevant Technical Note issued by the aircraft manufacturer - its proper accomplishment is to be entered in the log book by a licensed inspector.

### Maintenance and inspection

The materials used for the fabrication of the WEDEKIND safety sleeve are weather resistant. Under normal operating conditions corrosion will not occur. The safety sleeve therefore is maintenance-free. Lubrication with grease or oil will normally lead to fouling and gumming - so this should better be avoided. With the control rods connected, the safety sleeve is to be checked for correct function by verifying that it has slid properly and automatically over the end of the wedge-shaped locking cam.

The WEDEKIND safety sleeve consists of the following parts (shown cross-hatched in the above sketch):

1 off washer, $\phi$ 20 x $\phi$ 12,5 x 1,0 mm	Part 1
1 off bushing, $\phi$ 20 x 1,8 mm, length 6 mm	Part 2
1 off compression spring, $\phi$ 19 x 0,8 mm, length 20 mm	Part 3
1 off bushing, $\phi$ 20 x 1,8 mm, length 7 mm	Part 4
1 off safety sleeve, $\phi$ 23 mm, length 36 mm	Part 5
1 off roll pin, DIN 1481, $\phi$ 2 x 22 mm	Part 6

Dipl.-Ing.  
Klaus Wedekind  
Am Südhang 56  
D-57548 Kirchen  
GERMANY

WEDEKIND - SICHERUNG

Safety device for  
L'HOTELLIER ball and  
swivel connectors

Page 2 of 2



LBA signed:

*U. Hoff*  
10. Juni 1994

Hints for retro-fitting

With the "L'Hotellier" swivel joint unscrewed from the control rod (be sure to measure the length of engagement reach of its threaded shaft in the rod as otherwise a re-adjustment of the control surface is required), slide the components of the safety sleeve on the free end of the rod in the following order: ④, ③, ⑤ and ②. Re-install the swivel joint - with lock washer No. ① fitted to the threaded portion of the shaft - and screw it into the control rod until the correct length of engagement is obtained, then tighten lock nut.

Slide bushing No. ② 2 mm into the safety sleeve No. ⑤. Hold the bushing No. ④ in the position by fixing with an adhesive compound, e.g. Cyanoacrylate. Drill a 2 mm hole through the bushing and body of the "L'Hotellier" connector, at 90 deg. relative to the wedge-shaped locking cam and 19 mm from hole center to outer face of washer No. ①, as shown in the drawing. Drive the roll pin No. ⑥ into the hole to secure bushing No. ④ in position, leaving 1 mm protruding on either side. This 19 mm distance ensures that projecting ends of the roll pin are situated between the cut-outs of the safety sleeve with the latter in "locked" position - thus preventing the sleeve from rotating and becoming dislocated.

In case of a rotating movement of sleeve, even though it is pushed forward by the spring No. ③, the wedge-shaped locking cam of the "L'Hotellier" coupling will not be secured.

To secure the wedge-shaped locking cam properly, an overlap of the safety sleeve of 3 mm relative to the lower end of the slide is sufficient.

Should the travel of the safety sleeve be more, its front end can be shortened (by filing). This might be required in the case of swivel joints being screwed deeply into a control rod, allowing the sleeve - the travel of which is only limited by the length of the channel for the compression spring - to move too far forward.

The protruding portion of bushing No. ④ - visible when sleeve No. ⑤ is in the "locked" position - must be marked GREEN (width approx. 4 mm).

If, after having connected the "L'Hotellier" coupling, the full width of this green ring is not visible, but only 1 or 2 mm, the safety sleeve No. ⑤ has not fully moved over the lower end of the locking cam, so the "L'Hotellier" coupling is not secured. The cause ( a broken compression spring, for instance) must be resolved before the next flight.

Hints concerning non-adjustable "L'Hotellier" control rod coupling No. RZ 9.41

For retro-fitting the WEDEKIND safety sleeve, the "L'Hotellier" swivel joint must be drilled out from the control rod and re-riveted as per the aircraft manufacturer's relevant Technical Note.

Lock washer No. ① is omitted.

Maße ohne Toleranzangabe mittel DIN 7168	
Langen - Maß	Toleranz
0,5 - 6	± 0,1
6 - 30	± 0,2
30 - 120	± 0,3
120 - 315	± 0,5
315 - 1000	± 0,8
1000 - 2000	± 1,2

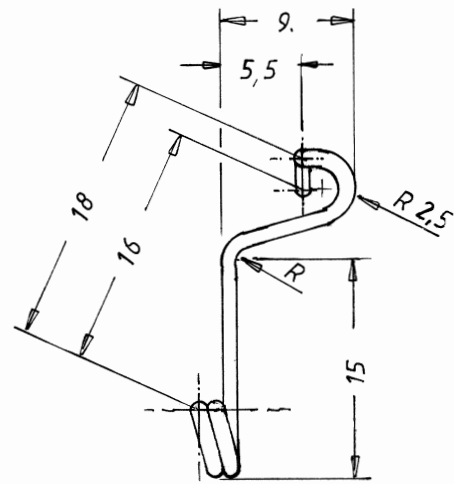
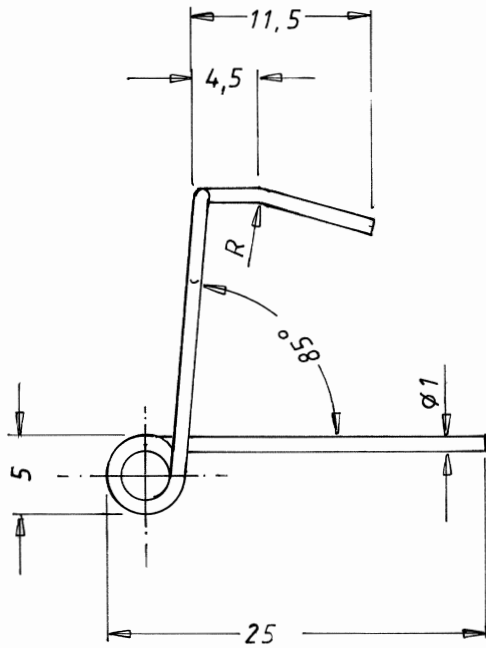

Zuwendungen verpflichten zu Schadenersatz. Alle Rechte für den Fall der Patenterteilung oder Gebrauchsmuster-Ertragung vorbehalten.

Weitergabe sowie Vervielfältigung dieser Unterlage, Verwertung und Mitteilung ihres Inhalts, nicht gestattet, soweit nicht ausdrücklich zugestanden.

**Federstecker - Montage am Beispiel ASW 22 / ASH 25 am L'HOTELLIER-Schnellverschluß der Wölbklappen-Stoßstange IX, AS-Nr. 220.45.0047 Flügel - Flügel - Trennstelle bei 3,8 m, rechts. Linke Seite spiegelbildlich montieren !**

**Example of clip spring installation for ASW 22 / ASH 25 at the L'Hotellier-quick connection of the flap control rod IX, AS-No. 220.45.0047 wing / wing intersection at span 3.8 m of right wing. Left wing: install like reflected image !**

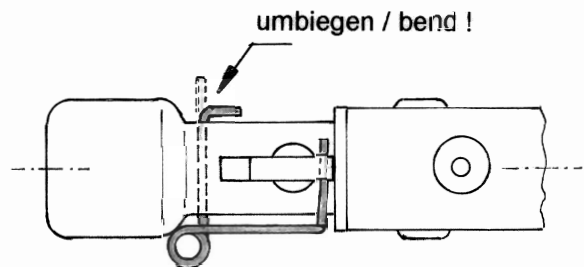
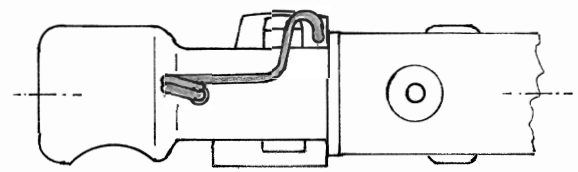

**1 Stück und  
1 Stück spiegelbildlich**

**1.4310 Federstahl rostfrei**

**Enden gratfrei**

St.	Benennung			Lfd. Nr.	Werkstoff		Rohmaße Teil- oder DIN-Nr.	Bemerkung	
				Datum	Name	Typ	Benennung	Maßst.	
				Bearb.	22.07.93	Juw	Federstecker für L'HOTELLIER-Schnellverschluß	2:1	
				Geprü.					
				Norm					
				A. Schleicher GmbH & Co		Zeichnungsnummer			Blatt
				Segelflugzeugbau 6416 Poppenhausen		99 000 2043			Bl.
Zust.	Änderung	Datum	Na.	Urspr	Ers. f.		Ers. d.		