

Subject: Additional ventilation of the wing nose boxes through the wing root rib.

Effectivity: All ASW 15 from serial number 15001 to 15163 inclusive, except 15014, 15042, 15048, and 15162.

Accomplishment: The modification is to be made until April 1st, 1972.

Reason: The ventilation of the wing nose boxes works through holes in the rear wing part. These ventilation holes in the aileron region of the wings are no more visible when the wing is assembled. For safety, a second possibility for the ventilation is bored through the forward wing root rib.

Instruction: Derigg the sailplane and bore the holes of about 1/2" diameter (10 to 15 mms). The rims of the holes must be coated with some paint afterwards.

Weight and Balance: negligible.

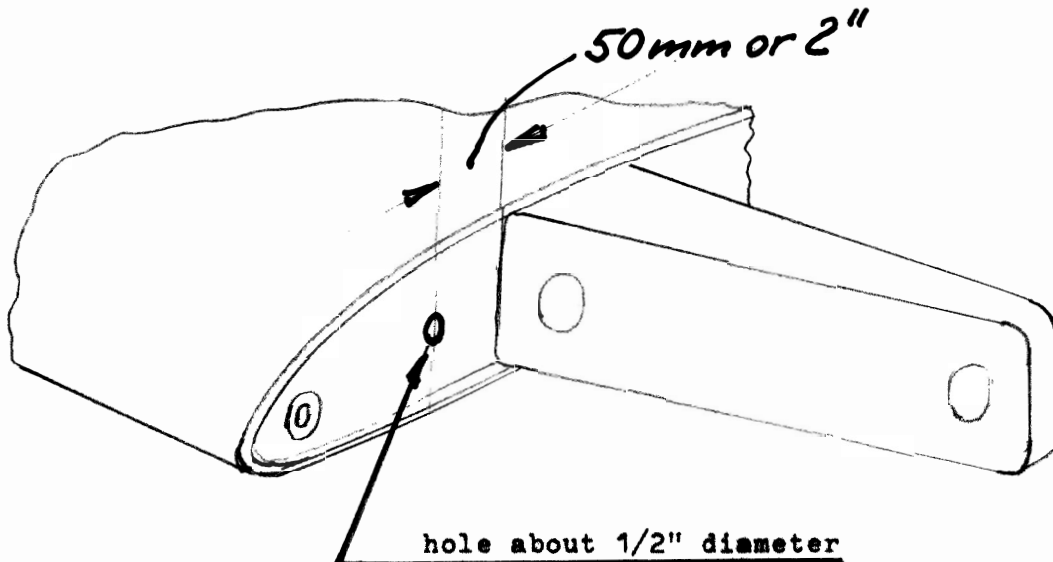

Poppenhausen, 20th October, 1971

ALEXANDER SCHLEICHER
Segelflugzeugbau

G. Waibel
(G. Waibel)