

Subject :

1. Inspection of the elevator actuator bellcrank.
2. Amendment to the Operations Manual.

Effectivity :

All ASW 15, ASW 15 B including existing modifications into motorgliders.

Accomplishment :

By March 1, 1982.

Reason :

With an ASW 15 the bellcrank actuating the elevator failed in flight (see attached sketch). Luckily the pilot could save himself by parachute. An inspection of the bellcrank showed that an older crack most likely caused by a hard landing some years ago resulted in fatigue failure of the bellcrank.

Instructions :

1. The elevator actuator bellcrank must be inspected for cracks. To do so the rudder has to be disconnected from the fin, as the inspection is possible through a hole of the fin spar (see attached sketch). The inspection area is not directly visible. However, with the finger-nail a major crack can be felt. Smaller cracks may be found by using a mirror and a small light which is fixed to a small strip of wood or a piece of wire.  
If no cracks are found, the rudder can be rigged again to the fin and safetied.
2. If cracks are found, the bellcrank must be exchanged against a new one, i.e. a bellcrank according to drawing 151.35.1011 (showing the correction note "TM 21 dated 24-11-81"). For carrying out this job the Repair Instruction "A" for the ASW 15 is to be used.
3. A copy of the inspection report must be sent to the manufacturer.

4. The Operations Manual pages 22 (ASW 15) or 27 (ASW 15 B) must be exchanged against pages 22A or 27A respectively. This measure is to guarantee that this inspection of the bellcrank will be repeated with each annual inspection and after hard load stresses (hard landings, crashes, etc.).
5. On page 3 of the Flight and Operations Manual the amendment to the Operations Manual as stated under the above point 4. must be certified.

Material : See drawing 151.35.1011 with the correction note "TM 21 dated 24-11-81".

Weight and Balance : Negligible.

Notes : If a new bellcrank is installed as mentioned under point 3 of the section "Instructions", it is recommended to install simultaneously the stronger plywood stiffeners of the ASW 15 B (see Repair Instruction "A").

Drawings : For this Technical Note 21 the drawings 150/151.34 M.11 \* been corrected and marked with the correction note "TM 21 dated 24-11-81".

\* and 151.35.1011 have

Poppenhausen, November 24, 1981

ALEXANDER SCHLEICHER  
Segelflugzeugbau

  
Gerhard Waibel.

The German original of this Technical Note is approved by LBA under the date of December 9, 1981, and is signed by SCHMALJOHANN. Translation has been done by best knowledge and judgement, in any case of doubt the German original is authoritative.

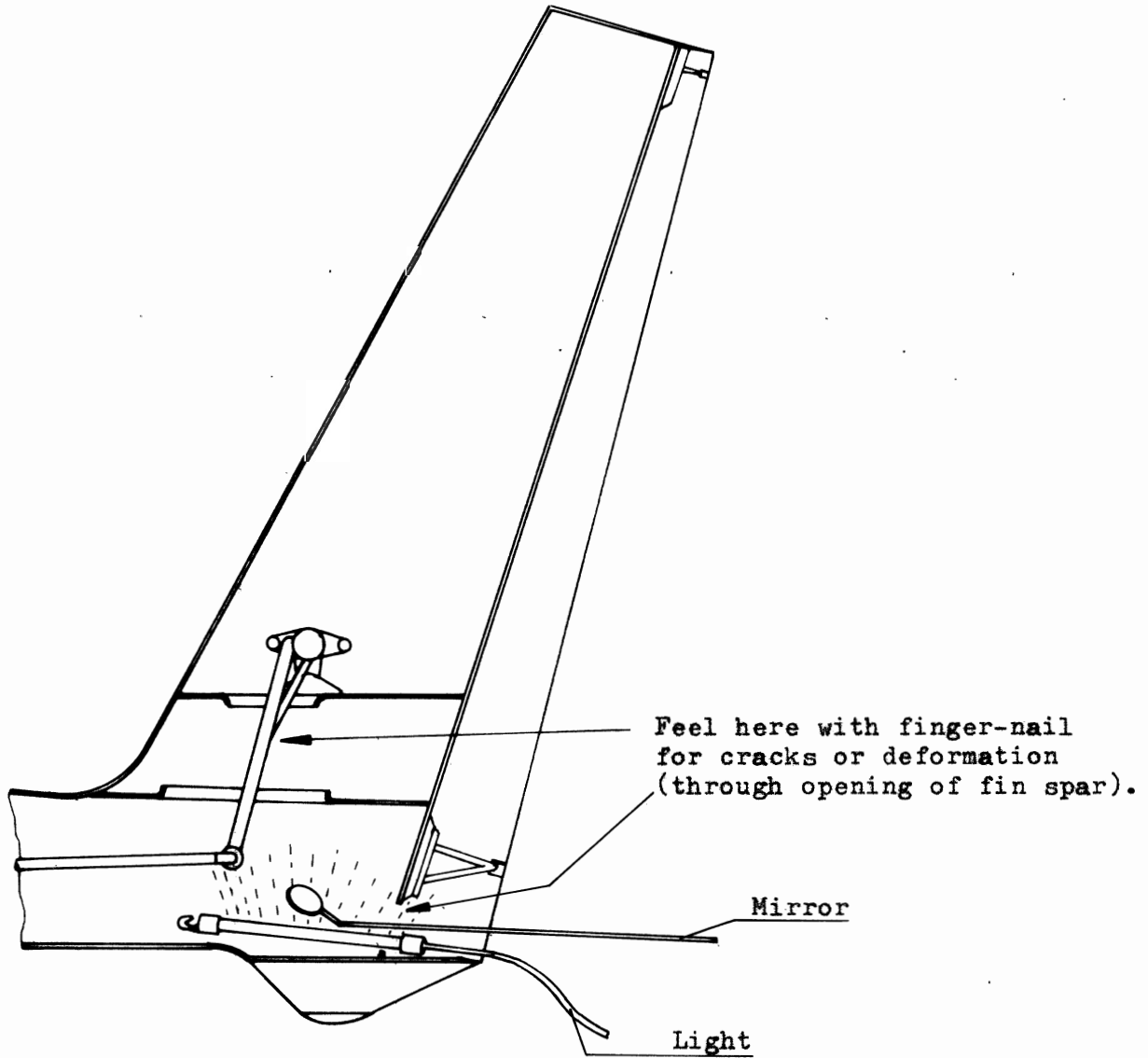

23 11 81 300