

Subject: Enlarging of the bolts at the wheel hub

Effectivity: Powered glider ASK 16

LTA Nr. 77/234

Accomplishment: Changing of the screws

Material: See drawing

Weight and balance: To be neglected

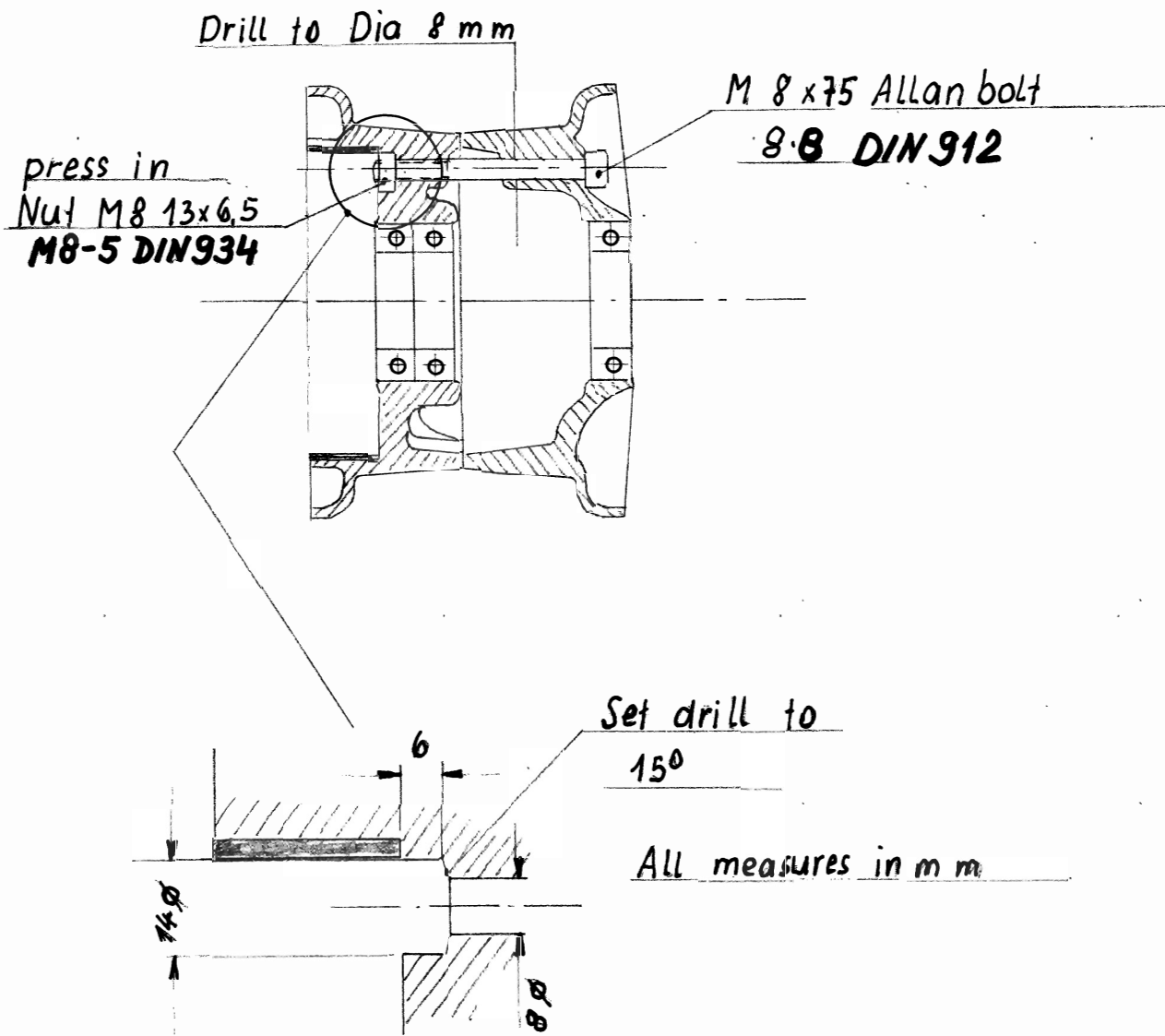

The modification has to be made until 31. Dez. 1977

It is recommended to send the hubs to Fa. Tost, 8000 München 2,
Thalkirchenerstr. 62, Tel. 089-534472 for making the modification.

Poppenhausen, the 05.07.77

Alexander Schleicher
ALEXANDER SCHLEICHER
Segelflugzeugbau