

**Subject:** Replacing of the elastic fairing tapes (elastic lip seal) at the control surface gaps of aileron, horizontal and vertical tail.

**Serial number applicability:** All ASW 28-18, ASW 28-18E

**Reason:** All ASW 28 series are fitted as standard with an elastic lip seal at the control surface gaps. The gaps at the aileron and at the elevator are sealed in addition by means of a Teflon sealing/slip tape (3M Scotch adhesive tape) on the hinge side. For the removal of control surfaces, e.g. for any maintenance or repair work, it is necessary to remove the relevant elastic lip seal and the sealing tape on the hinge side.

**Action:** When an elastic lip seal needs to be removed only for maintenance or repair purposes, please observe the following:

For the purpose of disassembly of aileron:

The elastic lip seal and the sealing/slip tape need to be removed only on the lower side (where the control surface hinges are located).

For the purpose of disassembly of elevator:

The elastic lip seal and the sealing/slip tape need to be removed only on the upper side (where the control surface hinges are located).

Disassembly of the rudder:

It is **not** necessary to remove the elastic lip seal at the fin.

1. Carefully remove the old elastic lip seal in order to avoid any de-laminations of the layers in this area. Remove any adhesive residue from the recessed step by means of synthetic resin thinners.
2. Accomplish any required inspection, maintenance or repair work at the control surfaces themselves and / or their hinges.
3. Cut the new elastic fairing tape and the sealing/slip tape into appropriate lengths (refer to the table under point "Material").

Note:

All surfaces must be completely clean, dry and free from dust and grease!

For cleaning of the glue areas pure "Nitro" thinner proved to be best (i.e. Fuldazell Spann- und Klebelack-Verdünnung 9600-01 from Rhodius). Then sand down protruding fibres which have been pulled out of the laminate by removing the old tapes. Use 220-grid sandpaper. When an inserted (not milled) step on the wing is found only clean and do **not** sand!

This can best be tested by sticking a transparent tape strip to the cleaned surface and then pulling it off again to check that no further dust particles adhere to it.

4. Wing lower side and horizontal tail upper side:

See Fig. 1 & 2

Apply the sealing/slip tape (1) (3M Scotch Teflon Tape) with a clearance of 16 mm to the front edge of the recessed step (22 mm wide).

Be careful that the sealing/slip tape (1) lies slack over the gap and that aileron are set to maximum negative deflection, whereas the elevator must be set to maximum positive deflection, so that later the Teflon sealing/slip tape is not stretched during normal full control deflections, so as to prevent full deflections.

Apply full deflections several times so that the sealing/slip tape (1) fits well into the gap; it must be firmly rubbed down on to the surface!

Then peel the protective backing from the elastic fairing tape, 38/15 (2), for the wings lower side and elastic fairing tape, 30/12 (3), for the elevators upper side - and firmly stick the fairing tape on abutting the front edge of the recessed step in the wing lower side and stabilizer upper side respectively, by means of its adhesive film layer.

Finally, press the adhesive zones of the elastic fairing tape (2) or (3) respectively firmly down to the surface by means of a soft wooden block (e. g.: Balsa) or a hard rubber roller!

For the horizontal tail in addition (see Fig. 2), a protective adhesive tape (5) is applied over the abutment of the front edge of the elastic fairing tape (3) and the step in the stabilizer. This tape should be as thin and moisture proof as possible; an example of a suitable tape would be white Tesa film No.104, 25 mm wide.

This protective tape serves to prevent the detachment of the front (leading) edge of the elastic fairing tape (elastic lip seal) which might result in dangerous flight characteristics.

5. Wing **upper** surfaces and horizontal tail **lower** surfaces:

See Fig. 3

Remove protective backing from elastic fairing tape, 30/12 (3) for the wings upper side and elastic fairing tape, 22/15 (4) for the horizontal tail lower side and stick it on abutting the front edge of the recessed step (about 15 mm wide) in the wing upper side and stabilizer lower side respectively, by means of its adhesive film layer.

Finally, press the adhesive zones of the elastic fairing tapes (3) & (4) firmly down on the surface by means of a soft wooden block (e.g.: Balsa), or a hard rubber roller!

Only for the stabilizer in addition (see Fig. 2), a protective adhesive tape (5) is applied over the abutment of the front edge of the elastic fairing tape (4) and the recessed step in the stabilizer.

No protective adhesive tape (5) is required on the wing.

6. Particular notes for the wing:

See Fig. 4 and 5

The Zig-Zag- or ZZ- turbulator tapes is fitted near the NACA intakes (see Fig. 4) and between outboard end of the ailerons and the wing tip (are shown in Fig. 5 and given in the table below under "Material").

Note:

Do **not** flatten the teeth of the ZZ- turbulator tape!

7. Vertical tail:

See Fig. 6

There are no recessed steps at the fin. As shown in Fig. 6 the elastic fairing tape, 30/12 (7) is stuck on over the rudder-fin transition at the left and right side, then pressed firmly down on the surface, and secured against detachment by sticking on a protective adhesive tape (5) over the abutment of the front edge of the elastic fairing tape (elastic lip).

**Material:**

	Wing		Horizontal Tail		Vertical tail left / right
	up	low	up	low	
(1) sealing/slip tape, Teflon tape, 30 mm wide		2 x 6,05 m	2 x 1,30 m		
(2) elastic fairing tape 38/15, scarved H: 0,25 mm K: 0,13 mm		2 x 6,05 m			
(3) elastic fairing tape 30/12, scarved H: 0,19 mm Kl: 0,22 mm	2 x 6,05 m		2 x 1,30 m		
(4) elastic fairing tape 22/15, H: 0,19 mm Kl: 0,22 mm				2 x 1,30 m	
(5) protective adhesive tape, Tesafilm Nr. 104, weiß, 25 mm			1 x 2,60 m	2 x 1,30 m	2 x 0,97 m
(6) Zig-Zag-Tape 60°, 12 mm wide, t = 0,52 mm, ZA = 7 mm		see A) & B)			1)
(7) elastic fairing tape 30/12, H: 0,19 mm Kl: 0,22 mm					2 x 0,97 m

\*) = Vertical tail, left and right

1) =see Maintenance Instruction B

A) = 6 times 0.03 m, lower wing surface in front of each NACA-intake, see Fig. 4

B) = 2 times 0.3 m, lower wing surface from outboard end of the aileron to the wing tip, see Fig. 5

H: = Hostaphan or Mylar tape

Kl: = Adhesive film

The material can be ordered from Alexander Schleicher GmbH & Co.,

Phone: ++49 (0)6658-890 or -8929, FAX ++49 (0)6658-8940,

or e-mail: info@alexander-schleicher.de

**Notes:**

1. The actions under points 1. through 7. can be accomplished by a competent person.
2. Ensure that the elastic fairing tapes (lip seal) is in tight contact even when the control surfaces are fully deflected.  
The secure and firm adhesion of the sealing Teflon-tape, the elastic fairing lip and the ZZ-(zig-zag) turbulator tapes must be checked.
3. The re-installation of Zig-Zag-Tapes for winglets, horizontal tail plane and vertical tail plane is described in **Maintenance Instruction B**.

Poppenhausen, May 14, 2004

**Alexander Schleicher**  
GmbH & Co.

by order

(Michael Greiner)

**Fig. 1 - Wing, lower surface**

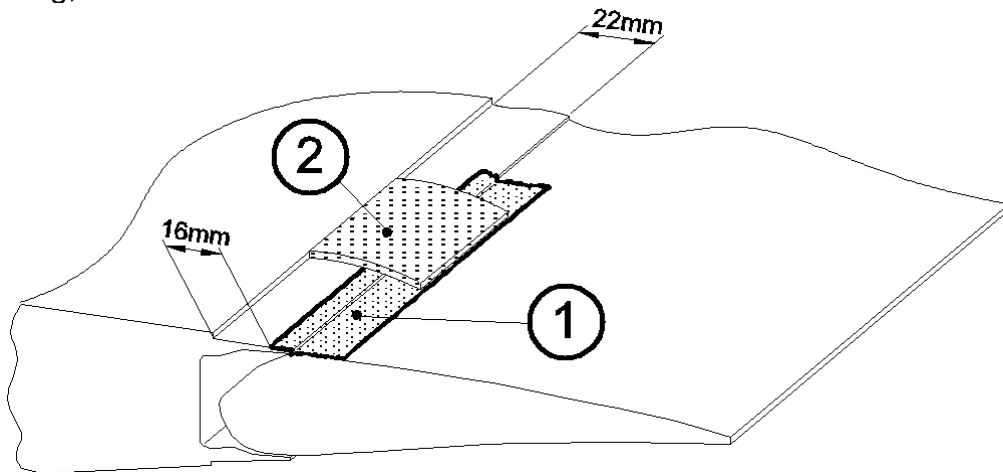

**Fig. 2 - Horizontal tail plane, upper surface**

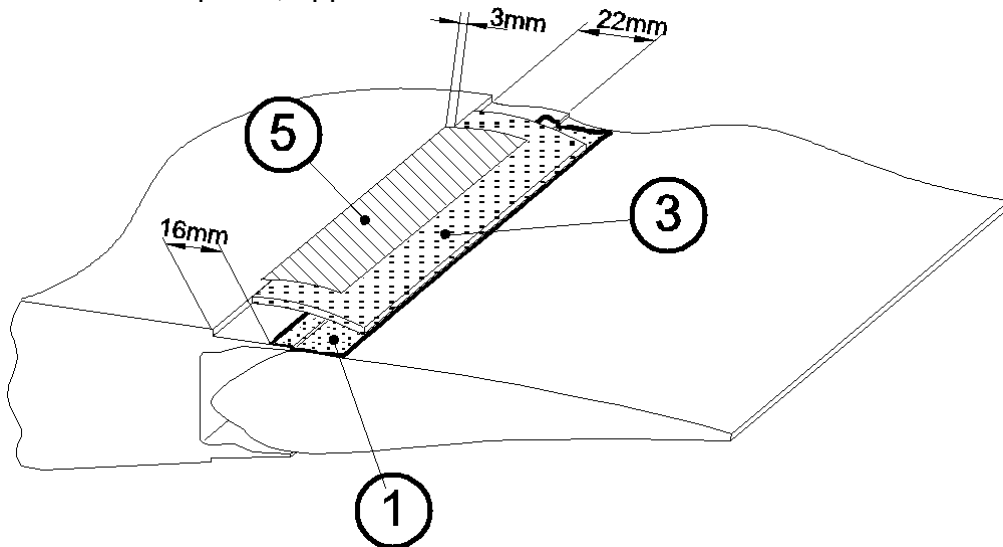

**Fig. 3 - - Wing, upper surface and horizontal tail, lower surface**

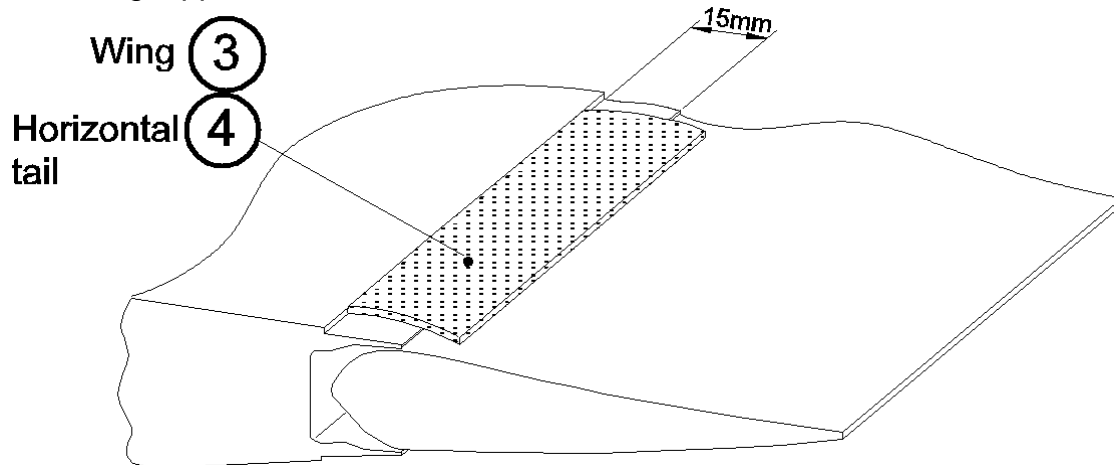

**Fig. 4 - Zig-Zag-Tape in front of the NACA-Intakes on the lower wing surface**



**Fig. 5 - Zig-Zag-Tape between outboard aileron end and wing tip on the lower wing surface**

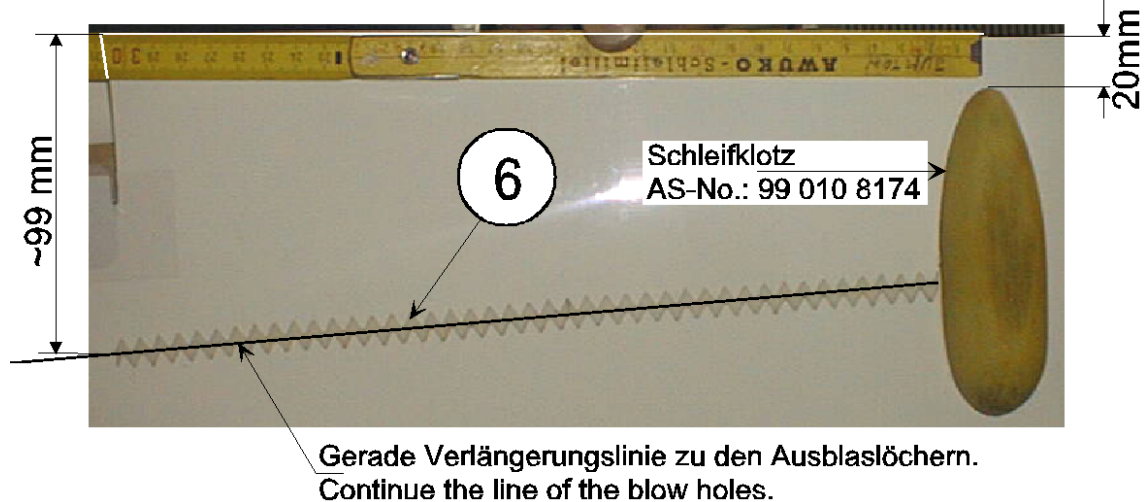

**Fig. 6 - Horizontal Tail**

