

Subject: Replacement of Turbulators (zig-zag tapes) on wings, winglets, horizontal and vertical tail

Applicability: All ASW 27-18 (ASG 29), ASW 27-18 E (ASG 29 E)

Reason: Modern profile sections as used for high performance sailplanes are designed in such a way, that they perform optimally when turbulators are installed. Therefore all ASW 27-18 are factory equipped with turbulators on the lower sides of ailerons and flaps. The blowholes are supplied with air from NACA ducts located in the control surfaces. In areas where it is not possible to install blow holes (control actuators, bearing locations on narrow control surfaces etc.) zig-zag tapes are installed as turbulators. zig-zag tapes are also installed in front of the NACA ducts in order to ensure optimum airflow to them. Damage or deformation (protruding or compressed jags at the front edge) can make replacing necessary.

Action: Zig-zag tapes of the specified kind are attached to the upper and lower surface of the horizontal tail, on both sides of the vertical tail, at the inboard surface of the winglets and at some positions on the lower side of the wing, according to the positions given in following drawings.

Note: All areas to be glued must be dried and cleaned from dust and grease as much as possible!

When applying the zig-zag tapes to the surfaces, the leading edges of the tapes must not be pushed in or rounded, as otherwise the aerodynamic effect of the turbulators may be impaired.

Material:

		Wing	Horizontal tail Upper side	Horizontal tail Lower side	Vertical tail left & right	Winglet Inner surface	in front of NACA intakes
[1]	Zig-zag tape 60° 0,5 mm thickness, 12 mm wide	Inner wing 2 x 0,4 m 15m-wing tip: 2 x 1,3 m 18m-wing-tip: 2 x 2,4 m	1 x 2,1 m	2 x 1,0 m	2 x 1,0 m		0,6 m
[2]	Zig-zag tape 60° 0,5 thickness, 6 mm wide					2 x 0,6 m	
[3]	Stickers Ø20 at the ends of the zig-zag tape		2 pcs.	4 pcs.		4 pcs.	

The material can be ordered from Alexander Schleicher GmbH & Co.,
Phone: ++49 (0)6658-890 or -8929, FAX ++49 (0)6658-8940,
Email: info@alexander-schleicher.de

Note: The action can be accomplished by a competent person.

Horizontal tail

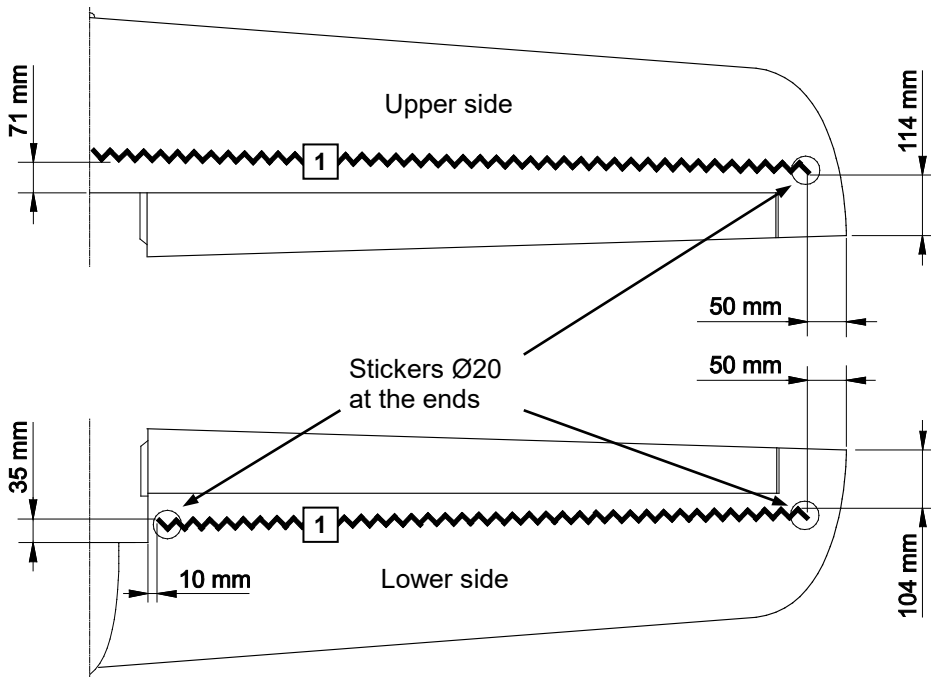

Vertical tail

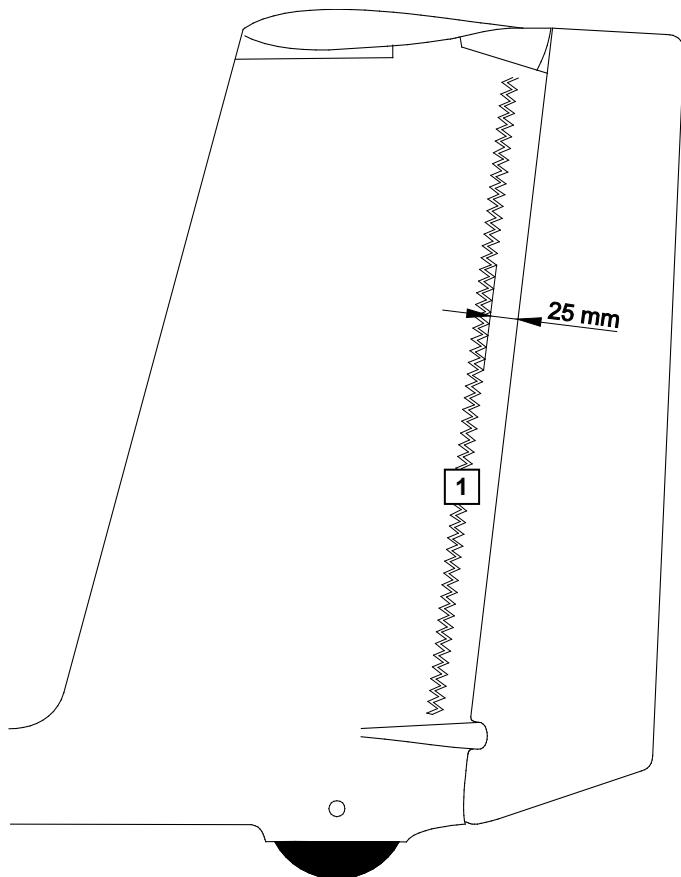

Winglet

Zig-zag tape only on the inside

Zig-zag tape [2] is affixed as a continuation of the winglet's zig-zag tape

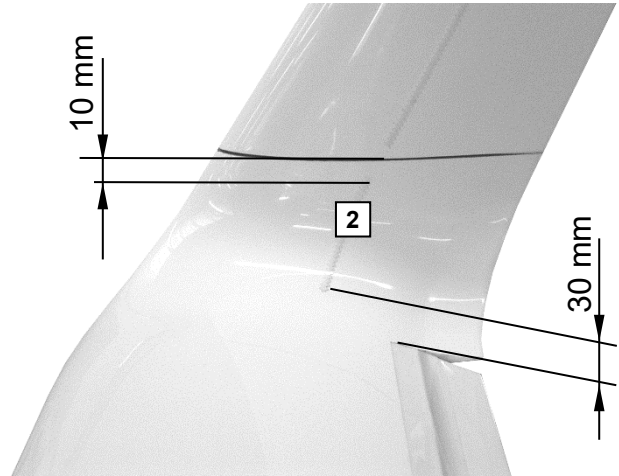
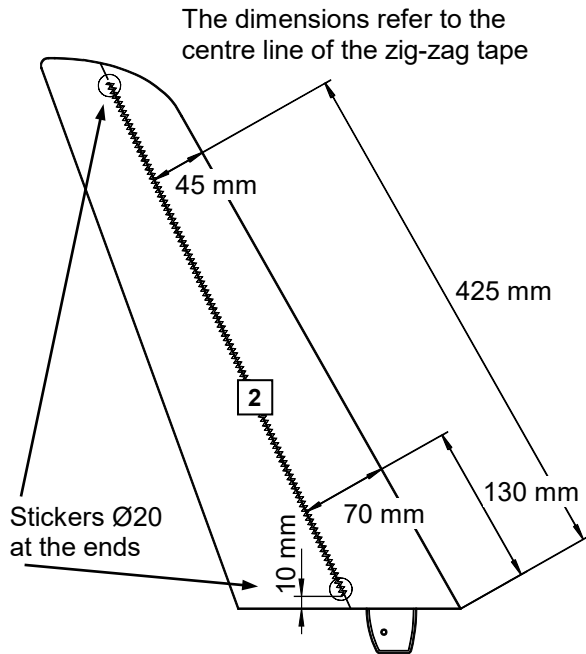

Wingtip (lower side)

In areas with blow holes, zig-zag tape [1] (100 mm wide) is affixed in all hinge locations. The trailing edge of the zig-zag tape is flush with the blow holes (Fig. 1). The blow holes should not be blocked.

In the outer section of the outer wings a zig-zag tape [1] is affixed at the trailing edge of the elastic fairing tape (Fig. 2).

18m outer wing: 1570 mm from the root rip to the outside.

15m outer wing: 1010 mm from the root rip to the outside.

Fig. 1:

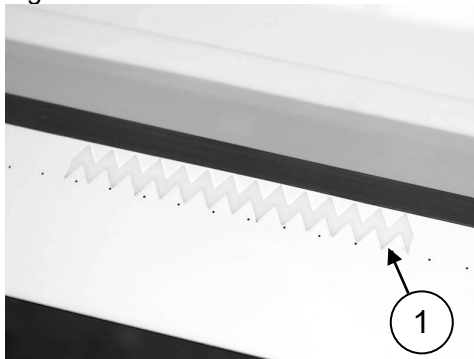
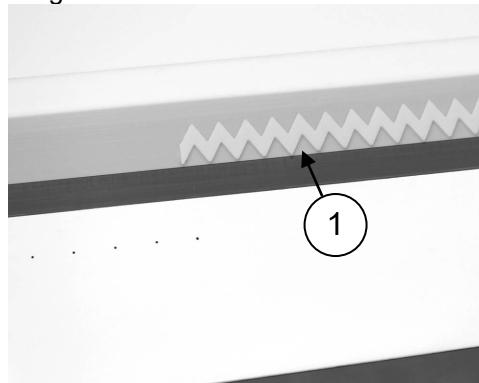
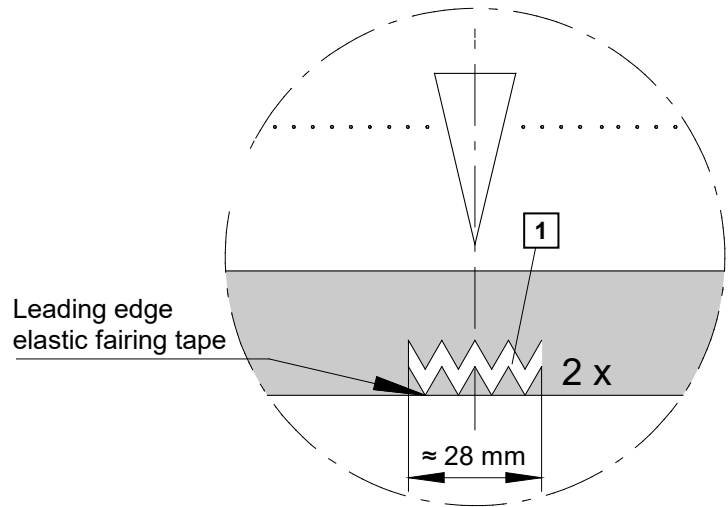

Fig. 2:



Particular notes for the wing

In front of each NACA inlet of the flap and the aileron, two zig-zag tapes [1] (any with 4 spikes), one on top of the other, are affixed at the leading edge of the elastic fairing tape.



A zig-zag tape [1] (100 mm wide) is affixed at the actuator of the aileron and the flap. The trailing edge of the zig-zag tape is flush with the blow holes.

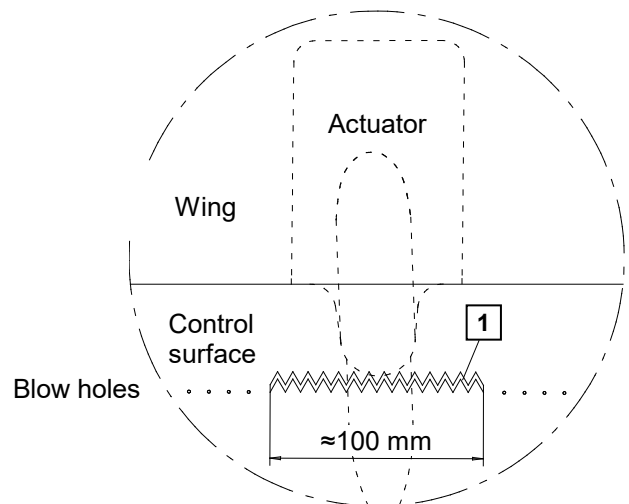

Poppenhausen, 20.11.2015

Alexander Schleicher
GmbH & Co.

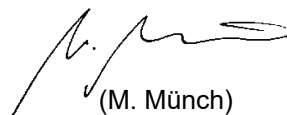
by order 
(M. Münch)