

Subject: **Replacing the elastic fairing tape at the control surface gaps and at the gaps of the engine compartment doors.**

Installing and replacing the turbulators on wings, horizontal and vertical tail.

Affected: All AS 34 Me

Reason: The control surface gaps of the AS 34 Me are covered as standard with elastic fairing tapes. The aileron and elevator gaps are additionally sealed by means of a sealing/slip tape on the hinge sides. The engine compartment doors are also covered with elastic fairing tapes.

For the removal of control surfaces, e.g., for any maintenance or repair work, it is necessary to remove the relevant elastic fairing tapes and the sealing/slip tapes on the control surface hinge sides.

On the horizontal stabilizer and in front of the NACA inlets on the wing, turbulator tapes (zig-zag tapes) are affixed. On the vertical stabilizer, there is a combined tape (zig-zag and elastic fairing tape). Damage or deformation can make replacement necessary.

Action: If the elastic fairing tape needs to be removed for maintenance or repair of the control surfaces, please observe the following:

For the purpose of disassembly of aileron:

The elastic fairing tapes and the sealing/slip tapes need to be removed only on the lower side (where the control surface hinges are located).

For the purpose of disassembly of elevator:

The elastic fairing tape and the sealing/slip tape need to be removed only on the upper side (where the control surface hinges are located).

For the purpose of disassembly of rudder:

It is not necessary to remove the combined tape on the vertical tail.

1. Carefully remove the old elastic fairing tapes respectively sealing/slip tapes in order to avoid any delamination of the layers in this area. Remove any adhesive residue from the recessed step by means of synthetic resin thinners. With careful handling a Rubber Eraser Pad can be very helpful.
2. Accomplish any required inspection, maintenance or repair work on the control surfaces themselves and / or their hinges.
3. Cut the new elastic fairing tapes and the sealing/slip tapes into appropriate lengths (refer to the table under point "Material").

Note: All surfaces must be completely clean, dry and free from dust and grease!

For cleaning of the glue areas Acetone (min. 99%) has proven to be best.

Wing lower side and horizontal tail upper side:

See Fig. 1

Apply the sealing/slip tape [1] with a clearance of 16 mm / 0.63 in. to the front edge of the recessed 22 mm (0.87 in.) wide step. Ensure that the sealing/slip tape [1] lies slack over the gap. The aileron is set to maximum negative (upwards) deflection and the elevator to maximum positive deflection (downwards). During normal full control deflections, the sealing/slip tape must not be stretched, so that full deflections are not hindered.

Apply full deflections several times so that the sealing/slip tape [1] fits well into the gap; it must be firmly rubbed down on to the surface!

Remove the protective backing from the elastic fairing tape 38/15 [2] for the wing lower and the horizontal tail upper side. Stick it into the recessed step of the wing's lower side resp. horizontal stabilizer's upper side, leaving no gap at the front edge. The elastic fairing tapes for the wings are scarfed on their trailing edge.

Finally, press the adhesive zones of the elastic fairing tape [2] firmly down on the surface using a soft wooden block (e.g.: Balsa) or a hard rubber roller! Make sure that the adhesive surface of the wing resp. stabilizer is not damaged.

Fig. 1 Wing lower side resp. horizontal tail upper side:

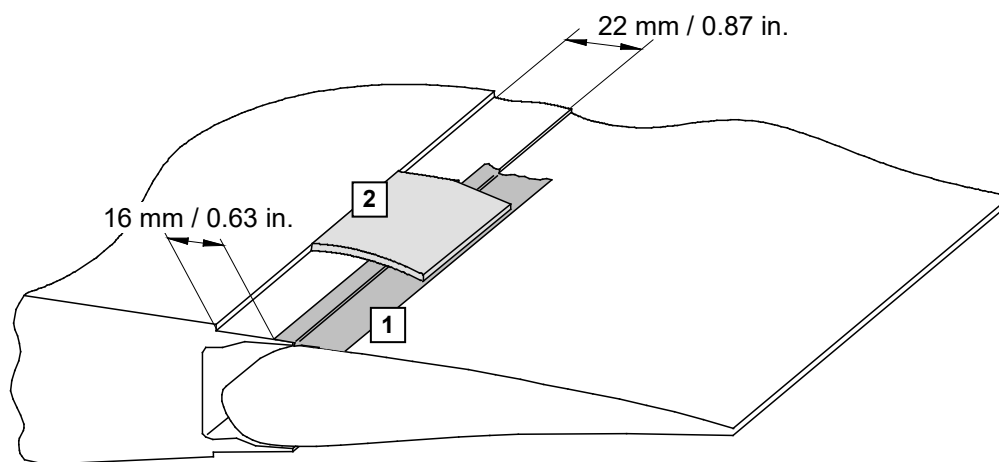

Wing upper side and horizontal tail lower side:

See Fig. 2

Remove the protective backing from the elastic fairing tape 30/12 [3] for the wing upper side and the elastic fairing tape 22/12 [4] for the horizontal tail lower side and firmly stick it into the recessed 15 mm [0.59 in.] wide step of the wing's upper side resp. horizontal tail's lower side, leaving no gap at the front edge. The elastic fairing tapes for the wings are scarfed on their trailing edge.

Finally, press the adhesive zones of the elastic fairing tapes [3] and [4] firmly down on the surface using a soft wooden block (e.g.: Balsa) or a hard rubber roller! Make sure that the adhesive surface of the wing resp. stabilizer is not damaged.

Fig. 2: Wing upper side resp. horizontal tail lower side:

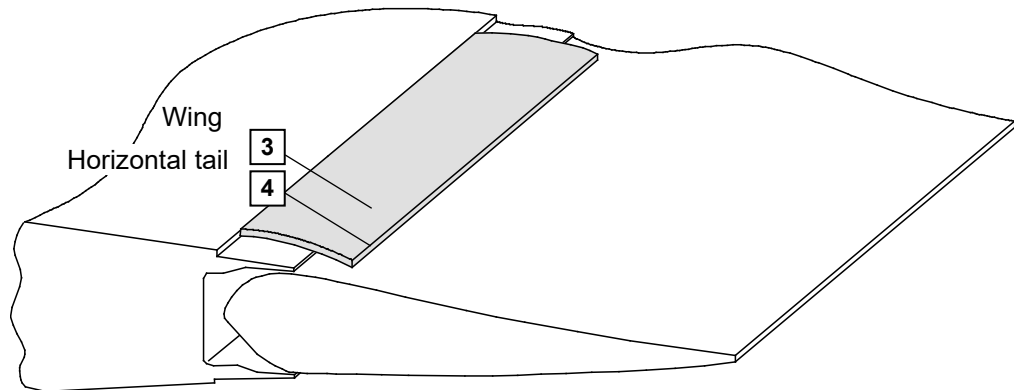

Special features of the wing

Fig. 3

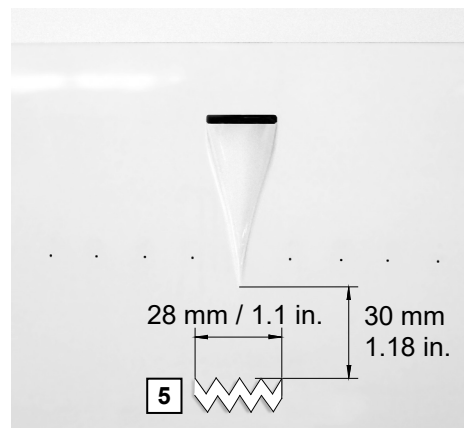

30 mm [1.2 in.] in front of the NACA inlets on the wing lower side, two zig-zag-tapes [5] (28 mm / 1.1 in. wide, 4 spikes each), one above the other, are placed.

Note:

Do not press down the tips of the zig-zag-tapes.

Fig. 4

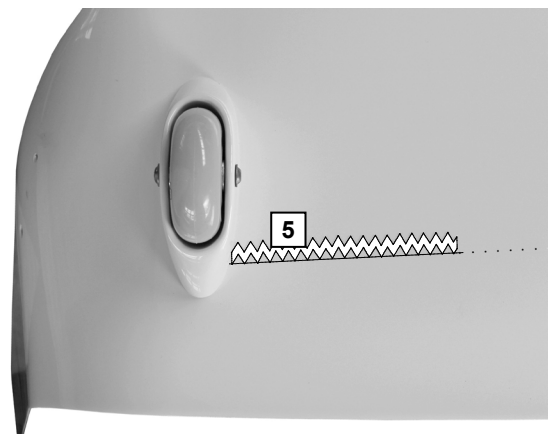

At the 15m outer wings, a zig-zag-tape [5] with a length of 130 mm [0.51 in.] is placed from the end of the blow holes and leads outwards. The trailing edge of the zig-zag-tape is flush with the blow holes.

Vertical tail:

See Fig. 5 to 7

There are no recessed steps at the fin. On both sides a combined tape (zig-zag and elastic fairing tape) 38/19/0.8 [6] is affixed with a distance of 20 mm / 0.79 in. from the spikes to the end of the fin. Press or roll it firmly down. Make sure that the adhesive surface of the fin is not damaged.

Fig. 5

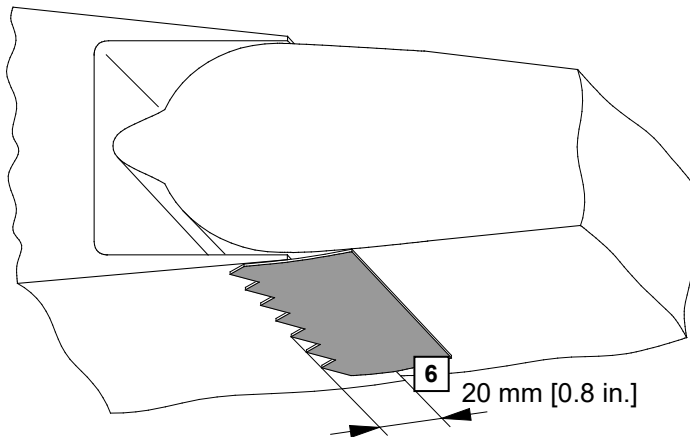
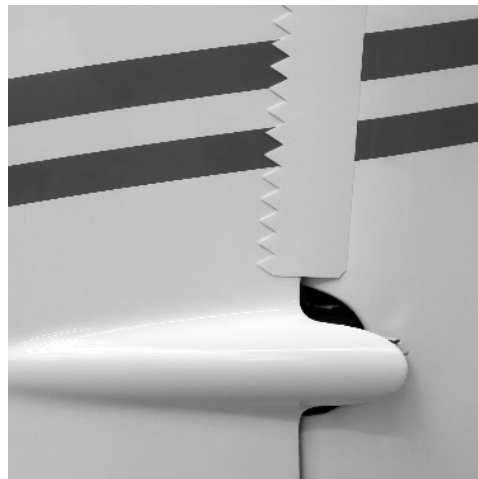

Fig. 6
Upper end



Fig. 7
Lower end



Engine compartment doors:

See Fig. 8 to 10

The elastic fairing tape 38/15 [8] is affixed along the lower edge of the engine compartment door with an overhang of 8 mm / 0.31 in. and pressed firmly down on the surface. The ends will be cut as shown in Fig. 8 and 9. At the contact point between the front and rear elastic fairing tapes a 25 mm wide piece of protective tape [9] is affixed over the bevel cut (Fig. 10).

Fig. 8:

Front end

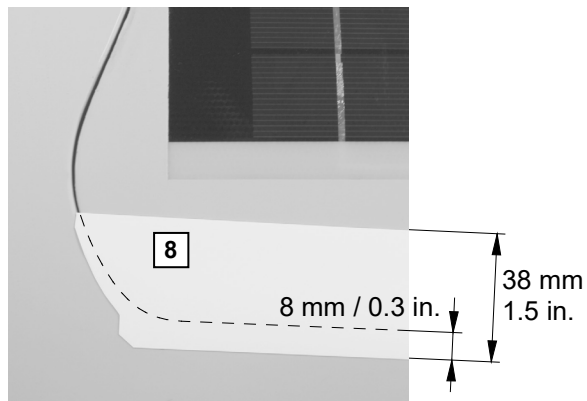

Fig. 9

rear end

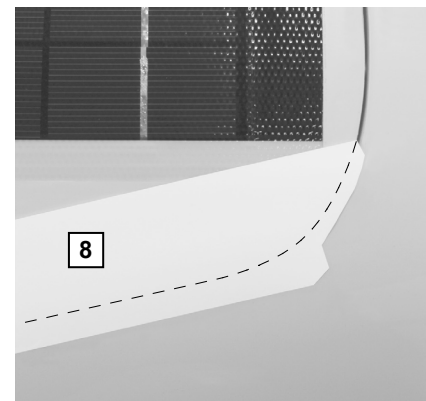
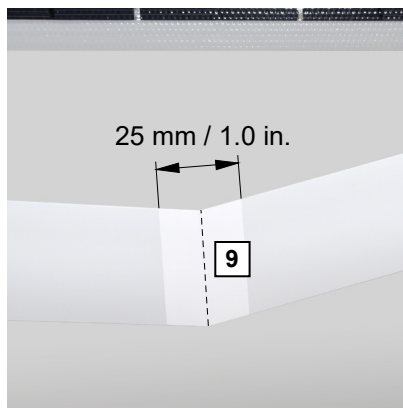

Fig. 10:

Connection



Zig-zag-tape on the horizontal tail:

Fig. 11

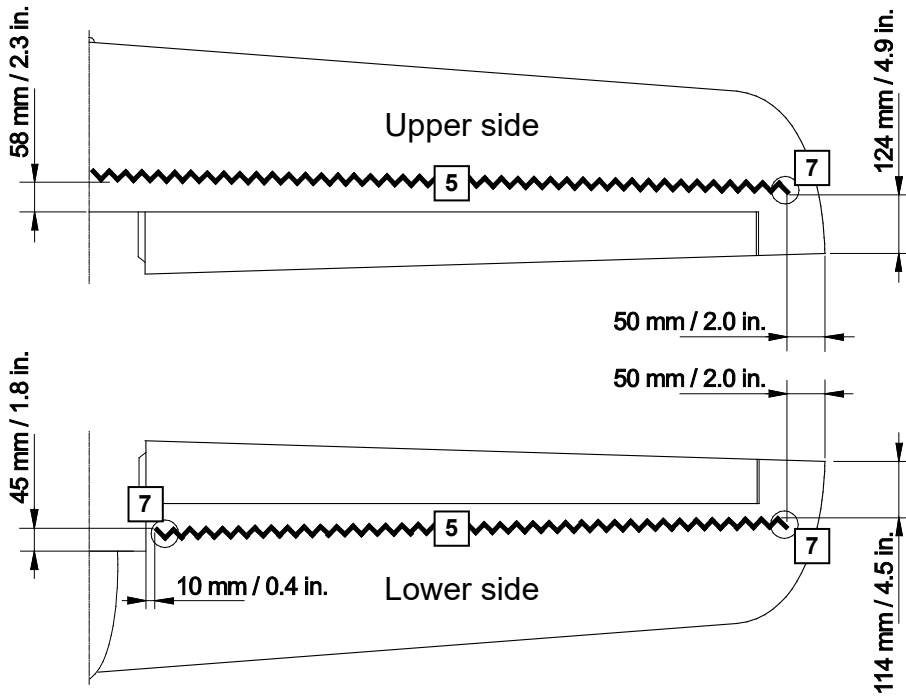

Material:

		Inner wing		Outer wing 18 m		Outer wing 15 m		Horizontal tail		Vertical tail
		upper	lower	upper	lower	upper	lower	upper	lower	both
[1]	Sealing/slip tape, 30 mm / 1.18 in. wide		2 x 1,3 m 4,3 ft		2 x 3.1 m 10.2 ft		2 x 1.9 m 6.3 ft	2.7 m 8.9 ft		
[2]	Elastic fairing tape 38/15 *, convex		2 x 1,3 m 4,3 ft (scarfed)		2 x 3.1 m 10.2 ft (scarfed)		2 x 1.9 m 6.3 ft (scarfed)	2.7 m 8.9 ft		
[3]	Elastic fairing tape 30/12 *, convex	2 x 1,3 m 4,3 ft (scarfed)		2 x 3.1 m 10.2 ft (scarfed)		2 x 1.9 m 6.3 ft (scarfed)				
[4]	Elastic fairing tape 22/12 *, convex							2.6 m 8.6 ft		
[5]	Zig-zag-tape 60° 7 mm distance be- tween tips, 12 mm wide 0.5 mm thickness		0.15 m 0.5 ft		0.15 m 0.5 ft		0.15 m 0.5 ft	1 x 2.8 m 9.2 ft	2 x 1.35 m 4.5 ft	
[6]	Combined tape 38/19/0,8 *									2 x 1.0 m 3.3 ft
[7]	Stickers Ø20 to protect the ends of the zig-zag-tapes							2 pcs.	4 pcs.	

Engine comp. doors

[8]	Elastic fairing tape 38/15, * convex	2 x 1.4 m 5.6 ft
[9]	Protective adhesive tape, Tesa film No. 104, white, 25 mm / 1 in.	0.1 m 4 in.

* The elastic fairing tapes are described with their width and the width of the adhesive film attached to it (e.g. 38 mm / 15 mm). **But it is also possible that the elastic fairing tape and the adhesive film are delivered as separate items.**

The material can be ordered from Alexander Schleicher:

Phone: ++49 (0) 6658-890
Fax: ++49 (0) 6658-8940
E-mail: info@alexander-schleicher.de

Poppenhausen, 04.02.2022

Alexander Schleicher
GmbH & Co.



(M. Münch)