

## 2.1 Introduction

This Section contains operating limitations, instrument markings and basic placards necessary for the safe operation of the powered sailplane ASK 21 Mi, and its standard systems, installations, and standard equipment as provided by the manufacturer.

The operating limitations included in this Section and in Section 9 are approved by EASA.

## 2.2 Airspeed

Airspeed limitations (indicated airspeed IAS) and their operational significance are shown below.

	Speed	IAS	Remarks
<b>V<sub>NE</sub></b>	Never exceed speed for calm air	<b>280 km/h</b> <b>151 kts</b> <b>174 mph</b>	Do not exceed this speed in any operation and do not use more than 1/3 of control deflection.

For flights beyond 2000m (6500 ft) altitude V<sub>NE</sub> must be reduced as prescribed in the placard included in Section 4.5.6.

**This placard must be affixed next to the A.S. I.**

<b>V<sub>RA</sub></b>	Maximum permissible speed for Rough Air	<b>180 km/h</b> <b>97 kts</b> <b>112 mph</b>	This speed must not be exceeded in strong turbulence. Examples of rough air are lee-wave rotors, thunderclouds, etc
-----------------------	---	--	---

<b>V<sub>PO</sub> max</b>	Maximum speed for extending and retracting the propeller	<b>120 km/h 65 kts 75 mph</b>	Do not extend nor retract the propeller outside of this speed range
<b>V<sub>PO</sub> min</b>	Minimum speed for extending and retracting the propeller	<b>90 km/h 49 kts 56 mph</b>	
	Maximum speed with propeller extended	<b>160 km/h 86 kts 99 mph</b>	Do not exceed this speed with the propeller extended

## 2.5 Power-Plant Control Unit Markings

The following table shows the markings of the digital ILEC engine control unit and the meaning of the colors employed.

Green Diode Normal Operating Range  <b>1800 to 7100</b>	Yellow Diode Caution Range  <b>7100 to 7750</b>	Red Diode with LCD blinking, impermissible range  at <b>7750</b> plus
--	--	---

### Permanent LC-Display:

RPM Indication (4 digits) <b>[RPM]</b>	Fuel Quantity (2-digits) <b>[Liter]</b>
<b>XXXX</b>	<b>0 to 23</b>

### Display reading when pressing the white button:

<i>Press 1 time:</i>	Liquid Coolant Temperature (3 digits) <b>[°C]</b>
<b>H2O</b>	<b>XXX</b>

<i>Press 2 times:</i>	Internal Cooling Air Temperature (3 digits) <b>[°C]</b>
<b>Air</b>	<b>XXX</b>

<i>Press 3 times:</i>	Current fuel consumption (4-digits) <b>[Liter/h]</b>
<b>Fuel</b>	<b>XX.X</b>

<i>Press 4 times:</i>	Engine Battery Voltage (4 digits) <b>[Volt]</b>
<b>U</b>	<b>XX.X</b>

## 2.6 Mass (Weight)

Max. Take-Off Mass::	705 kg (1554 lb)
Max. mass of all non-lifting parts:	510 kg (1124 lb)
Max. mass in baggage compartment (wing root):	each side 10 kg (22 lb)

## 2.7 Center of Gravity

The limits of the C.G. range are as follows:

forward limit	234 mm (9.22 in) aft of datum (BP)
aft limit	469 mm (18.47 in) aft of datum (BP)

"BP" (German: **B**ezugspunkt) stands in this context for "Reference Datum" which is identical with the wing leading edge at the wing root rib. One example of calculating C.G. positions is given in Section 6 of the ASK 21 Mi Maintenance Manual.

## 2.8 Approved Maneuvers

This powered sailplane is approved for normal sailplane and powered sailplane operation (Airworthiness Category "Utility").

Within the scope of this Airworthiness Category the following aerobatic maneuvers are approved – but only with the propeller tower retracted

- Spin
- Steep Climbing Turn
- Lazy Eight
- Loop upwards

## 2.9 Maneuvering Load Factors

## 2.10 Flight Crew

For solo flights the pilot must occupy the front seat.

With two up, the pilot in command occupies the front seat – unless the occupants agree prior to the flight that the pilot in command occupies the rear seat. This is only possible on the condition that all necessary operating elements and instruments are available in the rear seat and that the pilot is familiar with the operation of the aircraft from this position.

The minimum front seat payload is shown in the Operating Limitations Placard affixed in the front cockpit at the right wall (DATA and LOADING PLACARD).

One third of the weight of the rear pilot contributes to the payload in the front seat.

Lack of payload must be compensated by additional trim ballast weight. For this refer to the Mass and Balance Form in Section 6 and the description of trim ballast in Section 7.

## 2.11 Types of Operation

Flights may be carried out in accordance with day VFR. Cloud Flying is permissible in compliance with the extended minimum equipment (see Section 2.13).

### **NOTE**

*The legal regulations of the appropriate civil aviation authority with regard to any operational requirements have to be met. For example for US operators, "Cloud Flying" is considered flying in Instrument Meteorological Conditions (IMC) and requires an Instrument Flight Rules (IFR) clearance in the U.S.*

## 2.12 Fuel and Oil

Add **FUEL ONLY - WITHOUT** two-stroke oil mixed. Two-stroke oil must be added separately through the oil fill port.

Capacity of the fuselage tank:	23.2 Liter	6.13 US Gal
Max. fuel quantity usable in flight:	23.0 Liter	6.08 US Gal
Non-usable fuel:	0.2 Liter	0.05 US Gal

Approved Octane Rating: minimum 95 ROZ

Approved fuel grade: **preferably AVGAS 100LL**  
EUROSUPER, in compliance with EN228, or equivalent quality

In the USA "US 95 Octane rating" complies with the minimum requirements prescribed by the engine manufacturer.

Maintenance Instruction "Fuel" must be regarded, it is included in the Annex of the Maintenance Manual. For further data refer also to the Engine Manual IAE50R-AA.

### Engine oil:

*preferably* Silkolene Comp 2 Pre-mix (not Comp 2 Injector)

else: Bardahl KGR injection oil,  
Castrol Aviation A545  
Spectro Oils of America "Golden Spectro".

Oil tank capacity:	0.73 Liter	0.19 US Gal
Usable oil in flight:	0.70 Liter	0.18 US Gal
Non-usable oil:	0.03 Liter	0.01 US Gal

## 2.13 Minimum Equipment

Minimum Equipment consists of:

- 1 ASI indicating up to 300 km/h (162 kts), in each instrument panel
- 1 Altimeter, in each instrument panel
- 1 Magnetic Compass, in the front instrument panel
- 1 ILEC engine control unit, in each instrument panel
- 1 Rear view mirror
- 1 5-part seat harness (symmetrical), in each seat
- 1 parachute or back cushion (with about same thickness as a parachute, when compressed), for each pilot

For flights beyond the circuit of the airfield an aircraft radio is mandatory (for Germany). In addition, headphones should be worn when the engine is running.

**Caution:** When the engine is running, sufficient ear protection is strongly recommended!

For cloud flying the following instruments must be installed in addition:

- 1 Turn & slip indicator
- 1 Variometer

Approved equipment is listed in the Maintenance Manual in Section 12.1.

## 2.15 Operating Limitations Placard

This placard is fixed at the right cockpit side wall and contains the most important mass and speed limitations.

Segelflugzeugbau Alexander Schleicher GmbH & Co. Poppenhausen		Serial-No.:	<b>21</b>
Model: <b>ASK 21 Mi</b>			
<b>DATA and LOADING PLACARD</b>			
Empty Mass (Weight):	lbs	kg	
Max. Mass (Weight):	1554 lbs	705 kg	
Min. Front Seat Load Solo:	lbs	kg	
Max. Front Seat Load:	lbs	kg	
Max. Rear Seat Load:	lbs	kg	
Max. Total Combined Seat Load:	lbs	kg	
<b>Tire Pressure</b>	Main Wheel:	3.4 to 3.6 bar / 49 to 52 psi	
	Nose Wheel:	1.9 to 2.1 bar / 28 to 30 psi	
	Tail Wheel:	2.4 to 2.6 bar / 35 to 38 psi	
<b>Maximum Permissible Speeds with retracted Power-Plant</b>			
	Calm Air:	151 kts	280 km/h
	Manoeuvring Speed:	97 kts	180 km/h
	Winch and Autotow Launch:	81 kts	150 km/h
	Aerotow A/T:	97 kts	180 km/h
<b>with Power-Plant installed</b>			
	To extend/retract Propeller:	min. 49 kts	90 km/h
		max. 65 kts	120 km/h
	Propeller extended:	max. 86 kts	160 km/h
<b>Weak Link</b>			
	Winch Launch:	900 to 1100 daN (black)	
	Aerotow:	max 900 daN (brown)	

For reduced minimum cockpit load in the front seat by fitting removable trim ballast in front of the pedals: see Section 7.11.

The baggage compartment load in the wing roots must not exceed 10 kg (22 lbs) for each side.

**Baggage compartment max. 10 kg  
22 lbs**

This placard is fixed at the right cockpit side wall:

<b>Approved Aerobic Manoeuvres</b>
Aerobatics are only approved with retracted engine
<b>only without spin ballast:</b> Looping (positive) Lazy Eight Steep Turn
<b>with or without spin ballast:</b> Spin

This placard is affixed on the fuselage tank:

Avgas 100 LL or Super (car fuel grade)	
Fuselage Fuel Tank Capacity <small>ASK 21 MI</small>	
23.2Ltrs	6.1USGal
non usable fuel 0.2Ltrs	0.05USGal
<b>ATTENTION:</b>	
Check oil level in the oil tank!	

This placard is affixed on the right wall of the engine compartment near the oil tank:



If the aircraft has not installed the minimum equipment for cloud flying (see 2.13), this placard is located near the data placard:

**Cloud flying is not permitted!**

If the aircraft has installed the minimum equipment for cloud flying (see 2.13), this placard is located near the data placard:

**Cloud flying permitted  
as per flight manual**

### 3.1 Introduction

This Section contains Check Lists, summarizing procedures recommended in the case of emergencies, in the form of brief headings. This is followed by a more detailed description.

#### **EMERGENCY PROCEDURES**

(1)

To Jettison Canopies

- Ignition: **OFF!**
- Engage the propeller stop

##### **front seat**

- Move lever with red knob above the instrument panel to the left
- Push canopy upwards

##### **rear seat**

- Fully pull back both red canopy locking handles
- Push canopy upwards by the handles

(2)

Bailing Out

##### **front seat**

- Push instrument panel upwards
- Open safety harness
- Get up
- Roll over cockpit side
- Push off strongly
- Avoid wing & tailplane!
- Pull parachute

##### **rear seat**

- Open safety harness
- Get up
- Climb over cockpit side
- Push off strongly
- Avoid wing & tailplane!
- Pull parachute

### 3.3 Bailing Out

If bailing out becomes inevitable, first the canopy is jettisoned, and only then should the seat harness be released.

Front Pilot: Push instrument panel upwards (if this was not yet already done in the course of jettisoning the canopy). Get up or simply roll over cockpit side.

Rear Pilot: Get up - the supporting structure at either side of the instrument panel and the canopy arch serve as handholds - and climb out.

When jumping, push yourself away from the aircraft as strongly as possible.

**Avoid wing leading edge and tailplane!**

## 3.7 Engine Failure

### (1) Failure at Safe Altitude

- Fuel Valve: **OPEN** (foremost position)
- Ignition: **ON** (upward position)
- Power-Plant Main Switch: **ON** (ILEC responding)
- Master switch for engine battery: **ON** (ILEC responding)
- Fuel pump 2: **ON**
- Fuel: **Check fuselage tank contents**
- ILEC Change Over Switch: **Turned towards the pilot**

If the above points check out correctly, the fault cannot be rectified in flight, the propeller should be retracted and the ASK 21 Mi should from then on be operated as a pure sailplane. Retract propeller in the normal manner in accordance with the check list.

If necessary, carry out a normal sailplane outlanding.

### (2) Failure at Low Altitude

First check the points on the above check list.

- Fuel Valve: **SHUT!** (rearmost position)
- Ignition: **OFF!**
- Power-Plant Main Switch: **OFF!**
- Propeller Stop: **ENGAGED!** (bottom position)
- Leave the propeller extended
- Initiate outlanding

If the situation becomes so critical that a crash landing seems unavoidable because no landable terrain can be reached, the propeller stop should be engaged at a speed of about 90 km/h (49 kts) - even with the propeller still running. This will help to stop the propeller more quickly. Then retract the propeller at least to a "halfway in" position.

## 3.7 Engine Failure

### (1) Failure at Safe Altitude

- Fuel Valve: **OPEN** (foremost position)
- Ignition: **ON** (upward position)
- Power-Plant Main Switch: **ON** (ILEC responding)
- Master switch for engine battery: **ON** (ILEC responding)
- Fuel pump 2: **ON**
- Fuel: **Check fuselage tank contents**
- ILEC Change Over Switch: **Turned towards the pilot**

If the above points check out correctly, the fault cannot be rectified in flight, the propeller should be retracted and the ASK 21 Mi should from then on be operated as a pure sailplane. Retract propeller in the normal manner in accordance with the check list.

If necessary, carry out a normal sailplane outlanding.

### (2) Failure at Low Altitude

First check the points on the above check list.

- Fuel Valve: **SHUT!** (rearmost position)
- Ignition: **OFF!**
- Power-Plant Main Switch: **OFF!**
- Propeller Stop: **ENGAGED!** (bottom position)
- Leave the propeller extended
- Initiate outlanding

If the situation becomes so critical that a crash landing seems unavoidable because no landable terrain can be reached, the propeller stop should be engaged at a speed of about 90 km/h (49 kts) - even with the propeller still running. This will help to stop the propeller more quickly. Then retract the propeller at least to a "halfway in" position.

## 3.9 Other Emergencies

### (1) Groundloops

If the aircraft threatens to roll out beyond the intended landing area, the decision should be made not less than 40 m (140 ft) before reaching the end of the landing area to initiate a controlled ground loop.

- If possible, turn into wind!
- When putting down the wing, at the same time push the stick forward and apply opposite rudder!

### (2) Strong Noise Development Due To Defective Exhaust Silencer

If the noise from the exhaust silencer is considerably increasing, a failure of the exhaust system must be taken into account. Because hot exhaust fumes may cause fire, the engine must be stopped immediately or after reaching a safe height respectively. Prior to the next flight the exhaust system must be inspected and if necessary repaired.

### (3) Throttle Cable Broken

If the throttle cable fails, a spring at the throttle valve housing opens the throttle valve wide open and the engine is running at full throttle. Climb to a safe height, switch off the ignition, let the propeller run down so that it can be retracted in the normal manner.

If no airfield or landable terrain is nearby and further height gain is not possible, you may prevent a further climb by using the airbrakes. Then you may continue the flight in this configuration until you can reach an airfield. Prior to landing switch off the ignition and retract the propeller.

#### **(4) Defective Airbrake Control Circuit**

If sudden strong change of flight course happens, the pilot should immediately visually check that the airbrakes have extended on both wings as this asymmetry may be caused by an airbrake extended on one wing only. This problem could occur after a defect in the airbrake control circuit and cannot be compensated by rudder deflection. If the airbrake has extended on one wing only, the other airbrake must immediately be extended so far that the aircraft will regain level flight and the airbrake lever must be held in this position.

Depending on the flight height immediately initiate an outlanding.

### 4.3 Daily Inspection

- 1) Open canopies. Check main pins inserted up to the handle and secured.
- 2) Check control connections of ailerons and air brakes in the fuselage through the access hole at the left side above the wing. Check the proper use / engagement of the safety elements on the quick-release connectors. Finally, the access hole cover must be taped up!
- 3) Check cockpit and control runs for loose objects.
- 4) Check condition and operation of towing hooks, especially for soiling and free actuation. Engage and disengage the ring pair. Check the automatic release of the C.G. towing hook with the ring pair, which must release automatically backwards.
- 5) Check free movement of all controls. Check the plastic tubes inside the S-shaped tubes of the rudder pedals for correct and tight fit.
- 6) Check wheel brake. Pull the air brakes lever: with airbrake paddles fully extended the resilient brake pressure from the main brake (master) cylinder should be felt through the brake handle.
- 7) If your aircraft is fitted with a steerable nose wheel (optional), check its operation!
- 8) Check condition of Pitot tube in the fuselage nose!
- 9) Check tire pressure in the wheels!
- 10) Check the whole fuselage for damages, in particular the bottom side!
- 11) Check both upper and lower surfaces of the wing for damage.
- 12) Ailerons: Check condition, play and full and free movement. Check also the push rod connections.

- 13) Air brake: Check condition, free movement, alignment and locking.
- 14) Check the rear wing attachment pins for proper seating and locking.
- 15) Check that static ports in the fuselage tail boom are unobstructed!
- 16) Pressure probe on the tail boom or optional in the fin: Check condition and proper seating.
- 17) Check the condition of the rudder. Check the rudder for free movement, excessive play and proper securing of the cable connections.
- 18) Check tailplane for correct assembly and connection. Check elevator and actuator for condition, free movement and play!
- 19) Check control linkages of elevator, aileron, rudder and air brakes for free movement and for force-fit. Hold controls firmly at full deflection while loads are applied to stick, pedals and air brakes lever respectively.
- 20) Turn on master switch for engine battery. It can be left on for the day.

After rough landings or excessive flight stress the whole aircraft must be checked with the wings and tail unit removed. If any damage is found, a technical inspector must be called in. On no account one must take off again before the damage has been repaired.

- 13) Air brake: Check condition, free movement, alignment and locking.
- 14) Check the rear wing attachment pins for proper seating and locking.
- 15) Check that static ports in the fuselage tail boom are unobstructed!
- 16) Pressure probe on the tail boom or optional in the fin: Check condition and proper seating.
- 17) Check the condition of the rudder. Check the rudder for free movement, excessive play and proper securing of the cable connections.
- 18) Check tailplane for correct assembly and connection. Check elevator and actuator for condition, free movement and play!
- 19) Check control linkages of elevator, aileron, rudder and air brakes for free movement and for force-fit. Hold controls firmly at full deflection while loads are applied to stick, pedals and air brakes lever respectively.
- 20) Turn on master switch for engine battery. It can be left on for the day.

After rough landings or excessive flight stress the whole aircraft must be checked with the wings and tail unit removed. If any damage is found, a technical inspector must be called in. On no account one must take off again before the damage has been repaired.

## Daily Inspection with Extended Propeller

- a) When extending the propeller pay attention to unusual noise and stiffness of operation.
- b) The most important bolted connections can be checked from above through the open engine bay doors. With one exception they are secured with standard stop nuts, and therefore are easy to check. Particular attention must be paid to both front engine mounting screws and to the bolted connections of the extending toggle crank with jack head.
- c) The rear engine mounting screw which is running through the engine oil tank is secured with locking wire. Check this locking wire for damage.
- d) By pushing against the propeller assembly from the side and from the front, check the rubber elements of the engine mounting. The powerplant should react flexible and should not immediately move against the fuselage structure.
- e) Check the toggle over dead center of the drive mechanism of the propeller assembly! Check that both sides have a good over-center lock.
- f) Inspect the mounting of the exhaust silencer. The spring mountings can be checked by shaking the silencer.
- g) Check mounting of radiator, and the radiator support plate for incipient cracks.
- h) Check operation of throttle and propeller stop mechanism.
- i) Check Bowden cables, fuel lines and hoses for kinks. Check the condition of the elastic cords of the engine bay doors.
- j) Inspect lines (especially fuel lines and coolant hoses) and all components for signs of chafing.
- k) Check mounting of the flexible ram pipe. Check the secure seating of the air filter at the ram pipes upper end.

- l) Check limit switch for electric jack for damage and secure seating - including the electrical connections.
- m) Check the toothed belt for wear and correct pre-tension.

It should be possible to twist the belt just by  $30^\circ$  with normal hand force applied between the bottom belt pulley and one of the guide pulleys. This measuring method may be relatively imprecise, yet it may aid to recognise a considerably too low belt tension. Further notes on measuring and adjustment of belt tension are given in the Maintenance Manual, Section 2.

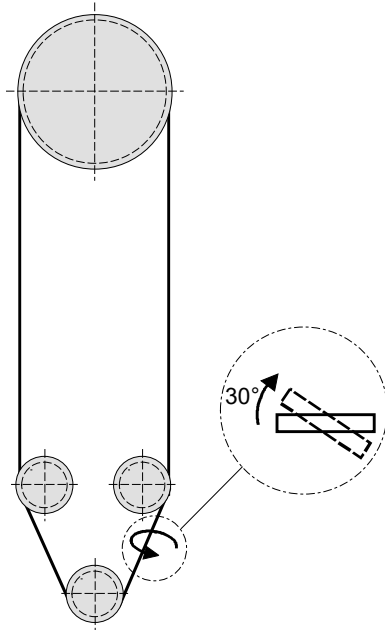

- n) Turn the propeller through by hand one time (Ignition OFF) and check for excessive friction, unusual noise and compression.

### Visual Inspection of the Propeller

- a) Visual inspection of the propeller as per propeller manual.
- b) Visual inspection of propeller mounting.

**Tank System (fuel and oil)**

- a) Check correct closing of the fuel tank cap.
- b) Check visually fuselage tank for leaks.
- c) Press drainer and release any condensation if present. Watch carefully that the drainer afterwards closes again tightly. The drainer is situated at the fuselage bottom left side below the wing.
- d) Check fuel tank vent opening. This vent is fitted next to the drainer.
- e) Check fuel contents for a safe take-off (min. 5 liters / 1.3 US gal)!
- f) Check engine oil tank (between engine and exhaust silencer) for signs of leakage. Check oil level and sufficient oil consumption (see also Section 7.8)

Always top up the oil tank to approx. 1 cm (0.39 in) below the filling hole.

## 4.4 Pre-Flight Checks

The following Check Lists containing the most important points are affixed within easy view of the front seat pilot:

### Pre Flight Check

1. Check main pins (secured)
2. Check control connections  
(Quick-release connectors must be secured)
3. Check cockpit and control runs for loose objects
4. Check and test tow release hooks
5. Check controls (positive connections, freedom of movement and play)
6. Check tire pressure and wheel brake
7. Check pitot tube in the nose
8. Check fuselage, wing and tail for damage
9. Check rear wing attachment pins (locked)
10. Check static pressure openings
11. Check TE probe
12. Check elevator and rudder
13. Check mass and balance
14. Check fuel contents
15. Check engine as per the manual

### Pre Take-off Check:

1. Remove tail dolly
2. Fasten parachute
3. If applicable connect rip-chord for automatic parachute
4. Take a correct seat position
5. Fasten seat harness  
(especially tighten lap straps)
6. Check free movement of the controls
7. Close airbrakes and lock them
8. Check spin ballast (optional)
9. Set trim in take-off position
10. Set altimeter
11. Check radio transmission
12. Check wind direction
13. Recap the take-off interruption procedure
14. Close and lock canopy

**Caution:**

Prior to solo flights the pilot must satisfy himself that both the switch of the fuel pump 2 and the ignition switch of the rear ILEC-control unit are "OFF"!

## 4.5 Normal Operation and Recommended Speeds

### 4.5.1 Power-Plant Control and Self-Launch

**Warning:** The access hole cover must be correctly locked and taped up. Non-observance risks that it may become loose and damage the propeller when the engine is running.

#### Checklist, extending propeller and starting engine

- Fuel valve: **OPEN**
- Power-plant main switch: **ON** (ILEC responding)
- With the ILEC change-over switch select the master unit
- Switch "Extend Propeller" engaged upwards
- Green LED "Propeller extended" on
- Propeller stop disengaged
- Ignition: **ON**
- Fuel pump 2: **OFF**
- Check fuel pump 1 (must be heard)
- Check ILEC for warnings
- Check ECU ready (ECU-LED constantly **RED**)

#### Cold and warm start on the ground (not too cold, OAT > 0°C/32°F)

- Propeller area CLEAR
- Throttle: IDLE (lowermost setting)
- Press STARTER button max. 5 seconds
- If engine does not fire, press STARTER again, after a short rest period for the starter battery
- Select throttle setting until the engine is running smoothly
- Check the red ECU-LED, must be OUT
- Allow engine to warm up at **4000 RPM** for 2 minutes (or up to a coolant temperature of 40°C / 104°F)
- Check ignition circuits at **6200 RPM**. Maximum drop 300 RPM.

**Cold start (very cold, engine heavily cooled down, OAT  $\leq 0^{\circ}\text{C}/32^{\circ}\text{F}$ )**

- Propeller area CLEAR
- Throttle: IDLE (lowermost setting)
- Press STARTER button max. 5 seconds
- If engine does not fire, press STARTER again after a short rest period for the starter battery
- Choose a throttle position at which the engine is running smoothly
- Check the red ECU-LED, must be OUT
- Allow engine to warm up at **4000 RPM** for 3 to 4 minutes (or up to a coolant temperature of  $40^{\circ}\text{C} / 104^{\circ}\text{F}$ )
- Check ignition circuits at **6200 RPM**. Maximum RPM drop 300 RPM.

**Cold and warm start in flight**

- Air speed 90 to 110 km/h (49 – 60 kts, 56 – 68 mph)
- Throttle: IDLE (lowermost setting)
- Press STARTER
- Check the red ECU-LED, must be
- If possible, allow engine to warm up
- Reduce airspeed and move throttle to Wide Open (watch rate of revolutions!)

field, before attempting a cross country flight. The power-plant of a powered sailplane must not be regarded as a life insurance, for instance when crossing unlandable areas. One should always be prepared for the possibility that the power-plant will fail to deliver the hoped-for propulsion. This may not necessarily be due to a technical shortcoming, but might be caused by nervous tension of the pilot (mistakes in carrying out starting procedure). The engine and its reliability should be regarded in the same light of a sailplane pilot's experience, that a thermal is not necessarily found when it is most urgently needed.

The engines of powered sailplanes are not subject to such stringent production and test regulations as normal aviation engines, and therefore cannot be expected to be quite so reliable.

A minimum safe height for extending the propeller and starting the engine must be met. The criterion is that it must be possible to retract the propeller again and carry out a normal sailplane outlanding if the engine cannot be started. A general valid value for this minimum safe height is about 300 meters (980 feet); however, this is depending also strongly on pilot ability and geographic factors.

### **(1) Extending the propeller**

Proceed as per checklist.

If the red ECU light goes out after switch-on of the ignition and then starts flashing after about 10 seconds, a defect must be suspected in some area of the electronic engine circuit. Such defect must be repaired prior to the next take-off. Further details on the flash error code are given in Section 7.7 in this Flight Manual or in the Engine Manual.

If - after the ignition is switched on - the red FUEL alarm light is still on, the fuel pressure is insufficient to get a flawless function of the injection system and to reach full engine output. Reason may be a fault with the fuel pumps or the pressure regulator, else possibly a leak in the fuel system.

**Warning:** In such a case the engine must be shut off immediately. No self-launch is allowed.

With the engine running the red ECU light normally is out. If it remains constantly on when the engine is running, a defect must be suspected in some area of the electronic engine control system. Such defect must be repaired prior to the next take-off. If the light turns on during flight, the flight may be continued provided that the engine is running normally. As the measuring sensors are partially double-existent, an error prompt will not necessarily take a direct effect on the engine performance. Yet if such error prompt occurs, all indicating elements should be constantly monitored to verify they meet the permissible values.

**Note:** Prior to the next take-off such defects must be repaired.

Allow engine to warm through on ground at 4000 RPM for 2 to 4 minutes (depending on ambient temperature) until the coolant temperature indicates around 40°C (104°F). This way it will be ensured that the engine will smoothly accelerate to max. RPM.

If the operating temperature is still too low (interior cooling air) the electronic injection system will adjust the RPM down. Only if the ground-test RPM has reached at least 7000 RPM and the engine is running smoothly, a safe self-launch can be carried out.

**Note:** Depending on the wind speed lower ground test RPM will be reached in a downwind while a headwind will increase the ground test RPM.

With temperatures below -10°C (14°F) the engine should not be started because there is the danger with a very cold engine that the lubricant oil is too thick and thus the oil feed into the engine could be interrupted.

### (3) Self-Launch

- ECU LED	<b>OUT</b>
- as a precaution fuel pump 2	<b>ON</b>
- after reaching safety height: fuel pump 2	<b>OFF</b>
- after 3 minutes max. take-off RPM: reduce to	<b>7100 RPM</b>

For a safe self-launch maximum engine revolutions should come up to 7000 RPM on the ground. With lower revolutions the pilot must face longer take-off distances than indicated in Section 5.2.3.

**Warning:** If maximum revolutions on the ground are below 7000 RPM, the aircraft must not take off. First a check must be done and a ground-test run. In case of doubt contact the manufacturer.

**Warning:** For the following reason it is prohibitive to switch over between the two ILEC control units during powered flight: If the ignition is set "OFF" at the control unit to which the pilot wants to change, then the engine fails, as the ignition power supply switches off during change over.

For the acceleration run and actual lift-off, the following practices apply: Trim and elevator neutral. Take-off run first on both nose wheel and main wheel. When sufficient speed is gained continue on the main wheel and gently pull the stick until the aircraft lifts off.

#### **(4) Climbing Flight**

During climbing flight, the engine should be run at maximum 7750 rpm and at  $v_Y$ . Pay attention that this take-off power is only allowed during the 3 minute limit.

#### **(5) Cruising Flight**

This can be carried out either in a saw-tooth pattern (climb followed by straight glide with propeller retracted), or in horizontal flight at 7100 rpm and an air speed of 125 km/h (67.5 kts, 78 mph). Monitor fuel state.

**High Speed Flight:**

The aircraft shows no flutter tendency within the permissible speed range. With airbrakes extended in a 45° dive the speed remains below  $V_{NE} = 280$  km/h (151 kts, 174 mph); at all up weight of 705 kg speed will be up to 251 km/h (136 kts, 156 mph).

Joint Airworthiness Requirements imply the following important consequences:

**Caution:** Fly within the yellow range in calm air only (no strong turbulence).

**Caution:** When exceeding maneuvering speed (i.e. yellow range on the ASI) full control deflections must not be applied. At  $V_{NE}$  (Red Radial Line) only one third of full control deflections are permissible any more.

**Caution:** Within the yellow range, airbrakes must only be extended under positive g-loads and only if the maximum load factor of 3.5g is not exceeded.

**Caution:** And generally the following applies: during strong gust loads do not use the full margin of control deflections. Simultaneous full gust loads and maneuvering loads can overload the structure.

### 5.2.3 Take-Off Performances

The take-off performances given below are applicable to take-offs on hard and level grass runways and for the aircraft, propeller, and engine in good condition and for the following conditions:

Airfield elevation	0 m NN
Temperature:	15 °C
Air Pressure:	1013 hPa
Take-off mass (with two pilots):	705 kg 1554 lbs
Speed ( $V_{IAS}$ ):	100 km/h 54 kts 62 mph

	Grass runway	Hard runway
Take off roll:	270 m 886 ft	215 m 705 ft
Take-off distance to 15 m (50 ft) height:	515 m 1690 ft	460m 1509 ft

The influence of air temperature and air pressure (airfield elevation) on take-off performance is given in the take-off charts (see Section 5.2.3.1.)

**Caution:**

In rain (wet wings) or with frost or ice on the leading edges, the aerodynamic quality of the aircraft is drastically reduced. Take-off is prohibited! First, wing and tailplane must be cleaned!

Tailwind as well as an uphill runway increase the take-off distances considerably. The possibility of abandoning the take-off must be considered, see also Section 4.5.1, point (3) Self-Launch.

If the cruise flight is done at  $v_H = 125$  km/h (67.5 kts, 77 mph) and at 7100 RPM, a fuel consumption of 14 l/h (3.7 US Gal/h) gives a flight time of 98 minutes from a full fuselage tank. This provides a range of 200 km (108 Nm). A gain in altitude, which could be used for glide, is not obtained. Fuel to warm up the engine and for taxiing was not subtracted.

The current fuel consumption is indicated on page 3 of the ILEC-LC Display as “fuel flow”. See Section 7.9 of this Flight Manual for additional information.

**5.3.2-1 Flight Polars**

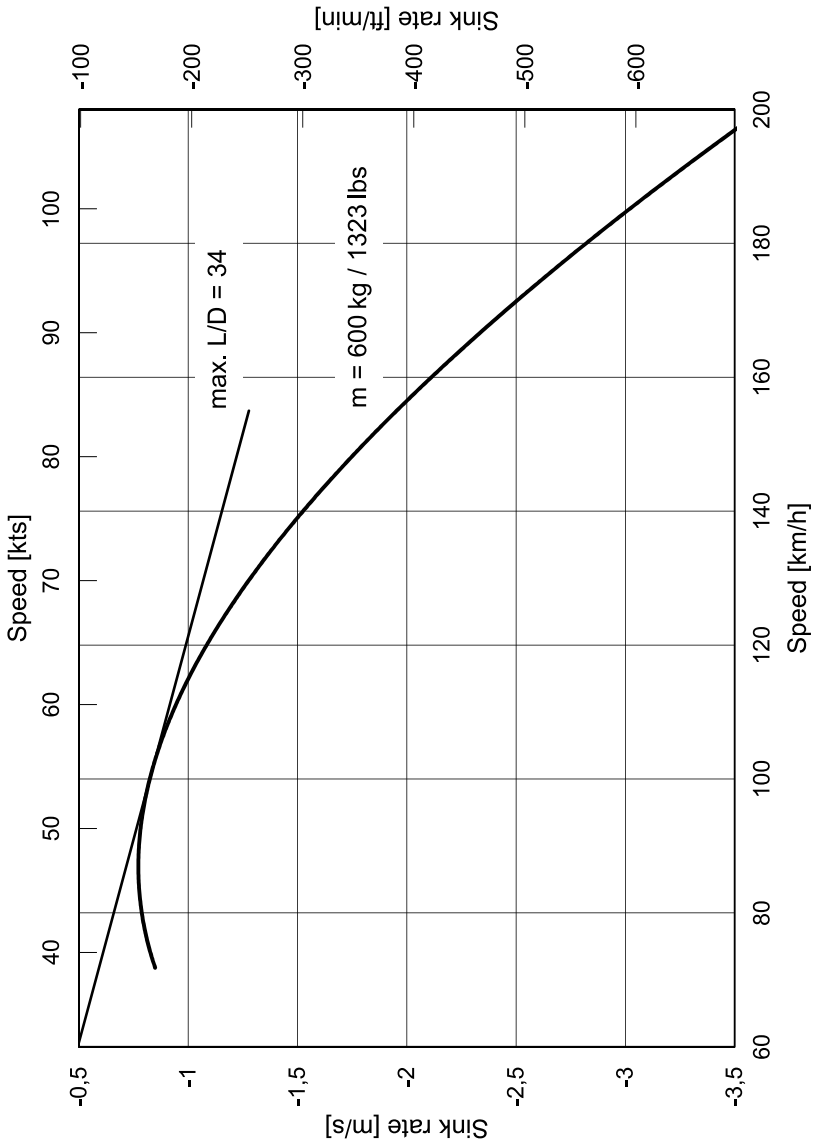

## Section 6

### 6. Mass (Weight) and Balance, C.G. Position

#### 6.1 Introduction

#### 6.2 Mass (Weight) and Balance Form

#### 6.3 Calculation of in-flight C.G.

## 6.1 Introduction

This Section describes the limits of load distribution, inside which the ASK 21 Mi can be safely operated.

Weighing procedure and calculation of permissible C.G. limits are described in the **Maintenance Manual**, Section 6. A complete list of the equipment which is installed in the aircraft during the weighing, is contained in the aircraft records together with a detailed weighing report.

## 6.2 Mass (Weight) and Balance Form

The Mass and Balance Form on the next page shows the maximum and minimum cockpit loads for both seats, as well as the total permissible load.

These mass and balance data must be calculated in accordance with the currently valid weighing report. The data and diagrams needed for establishing these are to be found in the **Maintenance Manual**, Section 6.

This Mass and Balance Form is only valid for the individual aircraft with the serial number specified on the title page of this manual!

For solo flights the pilot must sit in the front seat.

If the pilot mass in the front seat is less than the minimum stated in the Mass and Balance Form, this can be rectified by means of trim ballast weights to be fitted next to the nose tow release hook. In addition the following applies with regard to the minimum payload in the front seat: one third of the weight of the rear pilot contributes to the payload in the front seat.

The data for the minimum and maximum cockpit loads in both seats are applicable with empty fuel tank including the non-usable fuel quantity. Due to the position of the fuel tank the minimum load in the front seat is increased by 1 kg (2.2 lb) per 5 liter fuel (1.32 US.Gal.).

The baggage compartment load in the wing roots must not exceed 10 kg = 22 lb for each side (soft material).

Cockpit load includes pilot weights (including parachutes), baggage, fuel, and any equipment that was not included in the current weighing.

### 6.3 Calculation of in-flight C.G.

Description	Quantity	Weight	Lever arm	Moment
Empty weight and C.G.-position of empty aircraft (see page 6.3)		kg / lbs	mm / in.	kg·mm / lbs·in.
Pilot weight and lever arm, front seat (see page 6.5)		kg / lbs	mm / in.	kg·mm / lbs·in.
Pilot weight and lever arm, rear seat (see page 6.5)		kg / lbs	mm / in.	kg·mm / lbs·in.
Trim weight in front of rudder pedals	<input type="text"/> plates	3.0 kg / 6.6 lbs	- 1640 mm / - 64,6 in.	kg·mm / lbs·in.
Baggage compartment in wing root		kg / lbs	+ 250 mm / + 9,8 in.	kg·mm / lbs·in.
Fuel	<input type="text"/> liters / <input type="text"/> US-gal.	0.75 kg / 6.26 lbs	+ 900 mm / + 35,4 in.	kg·mm / lbs·in.
	sum weight =	kg / lbs	sum moment =	kg·mm / lbs·in.
	sum fuselage loading =	kg / lbs	<b>The sum of the fuselage loading has to be lower than the usefuel load in the fuselage!</b>	

in-flight C.G. =  $\frac{\text{sum moment}}{\text{sum weight}}$

The in-flight C.G. has to be within the limits given in section 2.7!

## Pilot Lever Arms

For the pilot lever arm the least favourable value must be used, unless the lever arm was established by weighing (the position of the back rest must be recorded). Masses in front of Datum have negative moment arms.

Designation	Lever arm referring to Datum	Remark
front pilot	-1185 mm to -1250 mm -46.6 in to -49.2 in	The less favorable value must be used
rear pilot	-77 mm to -80 mm -3.0 in to -3.1 in	The less favorable value must be used

to run. When the engine is running the light will be out if there are no errors.

A flashing of the ECU light indicates a problem in one of the following systems:

- Map #1 Sensor 1 1 ( Map =Manifold Pressure)
- Map # 2 sensor 1 2
- Intake Air Temperature 1 3
- Internal Cooling Air Temperature 1 4
- Supply Voltage 2 1
- Timing Sensor # 1 2 2
- Timing Sensor # 2 2 3
- Internal Electronic Errors other combinations  
refer to Engine Manual

The red flashing signal of the LED can indicate the error code only with engine standing still but with ignition switched on again. The above listed error codes - each consists of two numbers - are counted out in flashes according to the respective failure of a sensor. If there is for example an error in the Intake Air Temperature sensor, the red ECU-LED goes on when the Power-Plant Main Switch is set and after the ILEC Control Unit has finished its start-up check. If the ignition is now switched on, the LED extinguishes and after about 10 seconds it will start with the error code. (E.g. the code for 1 3: The light will flash once and after a delay of one second will then flash three times). This error code is repeated once. If more than one sensor is damaged, then each code will be flashed in sequence with 5 seconds between codes.

Systems which are triggered by the core system of the engine control unit (ECU), for example injection valve and ignition coils, are not subjected to an error checking. That means a failure of these systems is not indicated by flashing of the red ECU-LED **[10]**.

For more detailed information refer to the Engine Manual.

Fig. 7.7-2 Power-Plant Control Console, front

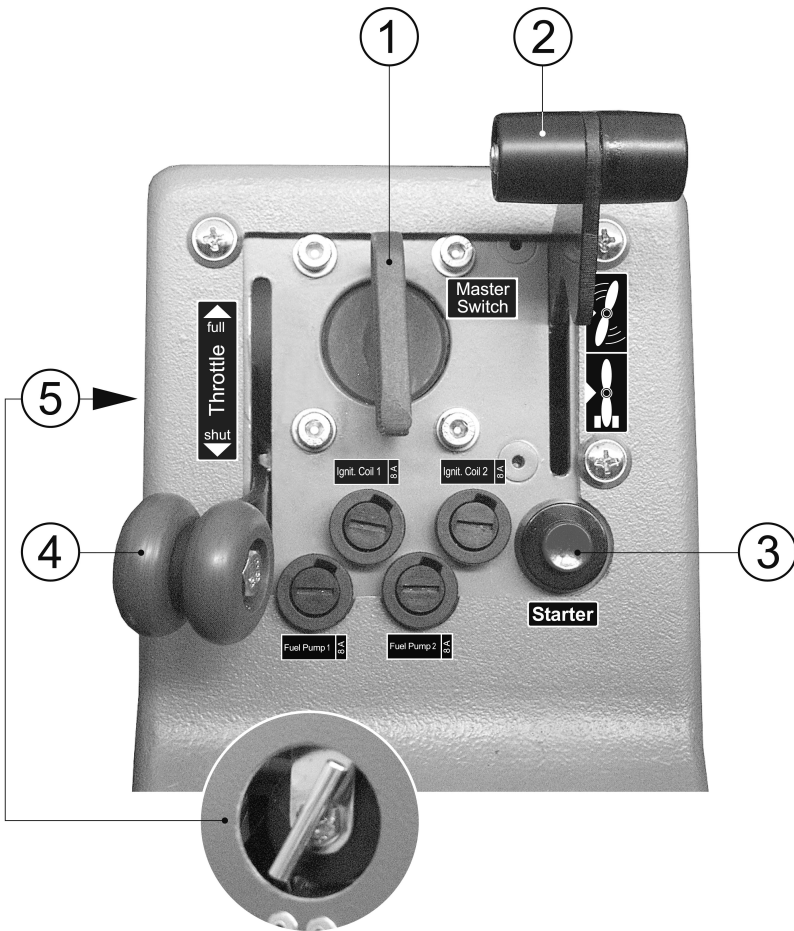

1. Main Switch for Power-Plant and Avionics (Engine Battery)
2. Propeller stop
3. Starter
4. Throttle
5. Adjusting twist knob for throttle friction brake

Fig. 7.7-2 Power-Plant Control Console, front

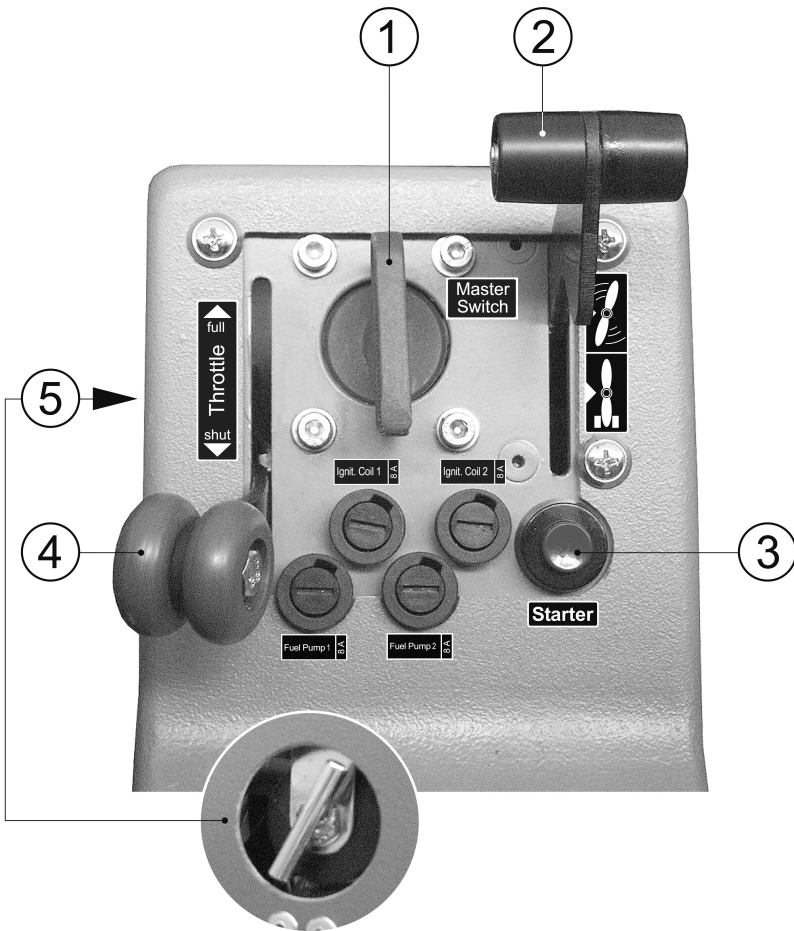

1. Master switch for engine battery
2. Propeller stop
3. Starter
4. Throttle
5. Adjusting twist knob for throttle friction brake

Fig. 7.7-3 Power-Plant Control Console, rear

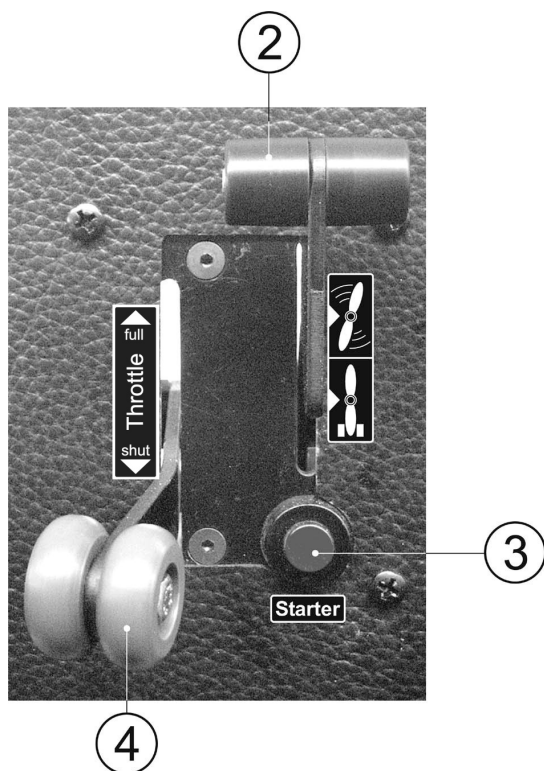

2. Propeller stop
3. Starter
4. Throttle

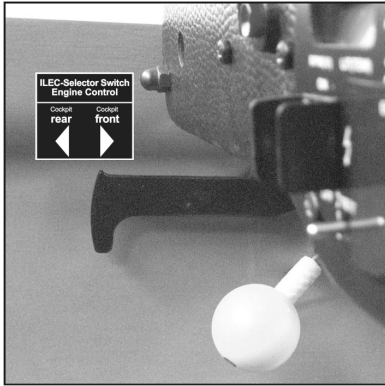
**Change-over switch between both ILEC engine control units:**

Change-over switch cockpit rear

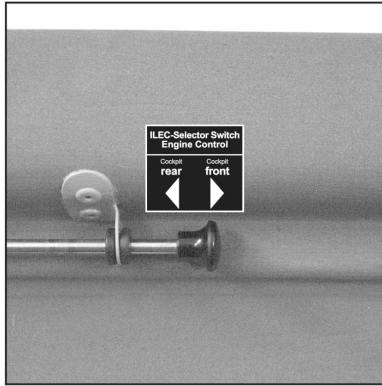

Change-over switch cockpit front

In each cockpit one ILEC control unit is installed. The ILEC change-over switch selects the master unit.

**Warning:**

For the following reason it is prohibitive to switch over between the two ILEC control units during powered flight: If the ignition is set "OFF" at the control unit to which the pilot wants to change, then the engine fails, as the ignition power supply switches off during change over.

Particularly for instruction flights we recommend generally that both pilots do all switching operations at the ILEC control unit synchronously (setting of the "Extend" / "Retract" switch and the ignition switch); this will prevent a different switch setting at the two units and thus exclude the above described situation.

## 8.4 Ground Handling / Road Transport

### (1) Parking

The ASK 21 Mi is equipped with plastic sealing tape at all control surface gaps. This means that when parking the aircraft principally all control surfaces must always be set to neutral!

#### In the open:

Parking of the aircraft in the open can be recommended only if foreseeable weather conditions remain suitable. It should be seriously considered whether the secure picketing, covering, and cleaning of the aircraft before the next flight may not demand more effort than de-rigging and re-rigging would have done.

For tying-down the wings: cradles (perhaps from the trailer) should be used which ensure that the ailerons cannot be stressed by the picketing ropes. There are tie-down holes in the wing tips.

**Note:** Parking in the open without protection against weather or light will reduce the life of the gel coat surface finish. Even after only a few weeks without intensive paint care, the polyester paint finish can become brittle and develop cracks.

**Caution:** The anti-freeze of the engine coolant liquid should be checked before the beginning of the cold season. If there is not sufficient anti-freeze in the coolant, the engine will be destroyed by deep temperatures!

#### In the hangar:

If the aircraft is parked in the hangar for protracted periods, it is recommended to cover only the Perspex canopy with a dust cover. On painted surfaces, dust covers may retain moisture from wet weather unnecessarily long. Moisture would impair the dimensional stability and even the strength of all fiber composite materials.

## Pre Take-off Check:

1. Remove tail dolly
2. Fasten parachute
3. If applicable connect rip-chord for automatic parachute
4. Take a correct seat position
5. Fasten seat harness (especially tighten lap straps)
6. Check free movement of the controls
7. Close airbrakes and lock them
8. Check spin ballast (optional)
9. Set trim in take-off position
10. Set altimeter
11. Check radio transmission
12. Check wind direction
13. Recap the take-off interruption procedure
14. Close and lock canopy

### Spin Characteristics

The ASK 21 spins in upright flight as well as in inverted flight.

**WARNING:** *Intentional spins are only permitted in upright flight.*

The ASK 21 spins fast, steeply, and combined with a pitch oscillation. The oscillation of the spin causes a variance in pitch attitude that can range from extremely steep to nearly flat. Thereby the nose can pitch up almost to the horizon and the cockpit noise can calm down nearly completely. The pilot may not be used to such flat phases from other gliders of plastic design. The oscillation is more pronounced with increased loading. Nevertheless, it is possible in all phases to recover from a spin within one additional turn. But there are some important points to be regarded.

**WARNING:** *The following important points have to be regarded during recovery (see Flight Manual page 13):*

- *Deliberately apply opposite rudder **up to the stop**, and keep it at the stop until the rotation ends.*
- *Short pause (approx. ½ turn) after applying rudder and before releasing the stick.*
- *As long as rotation has not stopped, only give in to the pressure of the stick. Do **not** push the stick.*

**CAUTION:** The washer and nut screwed on the cockpit placard (see above) **must** be used. After removal of the spin ballast the washer and the nut must be fixed again on the placard.

Higher masses in the cockpit and on the tail influence the rotational speed of the spin and the amplitude of the superimposed pitch oscillation. With higher masses, the average pitch attitude is approx.  $-40^\circ$  and the pitch amplitude is about  $\pm 30^\circ$ .

In all spins, the altitude loss is approximately 60 m (200 ft) per turn with a variance of 45 m (150 ft) minimum to 80 m (250 ft) maximum.

### Spin Entry Procedure

As specified in Section 4.5.9.

An aileron impulse against spin direction in due time can support spin entry.

**CAUTION:** *We recommend to enter spins in a generously safe altitude.*

For example it may be recommendable to enter the spin not below 1000m (3280 ft) AGL, when you intend to spin one turn and then recover. If you want to spin three turns and then recover, do not enter the spin below 1300 m (4270 ft) AGL

When determining your minimum altitude for entering a spin, always bear in mind, that the student may not recover correctly at first go, or other imponderability may happen. For example, recovery may be postponed by three additional turns during a wing drop or spin, when forward stick was applied before opposite rudder.

**WARNING:** *If a spiral dive sets in, opposite rudder, opposite aileron, and relaxed back stick pressure must be used immediately to prevent overstressing the structure.*

If cockpit noise due to outside airflow continues to increase to the point that conversation between crewmembers is difficult, or if the airspeed indicator is increasing through 110 km/h (60 kts), the aircraft is no longer spinning but is likely in a spiral.

## 2.15 Operating Limitations Placard

The following placards replace the respective placards of the powered sailplane:

Segelflugzeugbau Alexander Schleicher GmbH & Co. Poppenhausen		Serial-No.:	<b>21</b>
Model: <b>ASK 21 Mi, with engine removed</b>			
<b>DATA and LOADING PLACARD</b>			
Empty Mass (Weight):	<input type="text"/> lbs	<input type="text"/> kg	
Max. Mass (Weight):	1320lbs	600kg	
Min. Front Seat Load Solo:	<input type="text"/> lbs	<input type="text"/> kg	
Max. Front Seat Load:	<input type="text"/> lbs	<input type="text"/> kg	
Max. Rear Seat Load:	<input type="text"/> lbs	<input type="text"/> kg	
Max. Total Combined Seat Load	<input type="text"/> lbs	<input type="text"/> kg	
<b>Tire Pressure</b>	Main Wheel:	<input type="text"/> 3.4 to 3.6 bar / 49 to 52 psi	
	Nose Wheel:	<input type="text"/> 1.9 to 2.1 bar / 28 to 30 psi	
	Tail Wheel:	<input type="text"/> 2.4 to 2.6 bar / 35 to 38 psi	
<b>Maximum Permissible Speeds</b>			
Calm Air:	<input type="text"/> 151 kts	<input type="text"/> 280 km/h	
Manoeuvring Speed:	<input type="text"/> 97 kts	<input type="text"/> 180 km/h	
Winch and Autotow Launch:	<input type="text"/> 81 kts	<input type="text"/> 150 km/h	
Aerotow A/T:	<input type="text"/> 97 kts	<input type="text"/> 180 km/h	
<b>Weak Link</b>			
Winch Launch:	<input type="text"/> 900 to 1100 daN (black)		
Aerotow:	<input type="text"/> max 900 daN (brown)		
<b>Permissible Load factor <i>only with engine removed</i></b>			
positive:	<input type="text"/> 6.5 g		
negative:	<input type="text"/> - 4.0 g		

<b>Approved Manoeuvres</b>
In condition with engine removed according to Flight Manual 9.B!
<u>Only without Spin Ballast</u> Loop upwards, Stall turn Half loop and half roll, Chandelle, Split 'S', Steep climbing turn, Slow roll
<u>With and without Spin Ballast</u> Spin

## 3 Emergency Procedures

There are no changes for the emergency procedures.

## 5 Performance

Because of the lower wing loading the stall speed decreases by about 6 km/h (3.2 kts, 3.7 mph).

## 6 Weight and Balance

A Mass and Balance Form must be available which must be headlined with "ASK 21, MTOW 600kg" and filled in according to the mass limits as stated under Section 2 of this supplement (Page 9.B.11).

Of course the spin ballast table (which was calculated for the aircraft with engine installed) is no longer valid! If necessary a new one can be requested and filed (Page 9.B.12).

### Wheel brake system

If the action of the wheel brake is found to be poor or altogether ineffective, this may be due to the following causes:

1. Brake linings may be worn and needing renewal.
2. Air may have entered the brake system and necessitate bleeding of the brake.
3. No brake fluid in the system; check brake system for leaks, replenish brake fluid and bleed system.

Air in the brake system will cause an increased actuating travel at the air brake lever. Taking in account the elasticity of the hose etc. one may assume that there is no air in the system, if the resilient travel does not exceed 50 mm (1.97 in) for an actuating force of 20 kp (44 lbf) at the air brake lever.

**Note:** *It is necessary to ensure that air brakes and hydraulic wheel brake are accurately adjusted relative to each other.*

The master cylinder acts also as the stop for the air brake control linkage: The hydraulic system must be adjusted at the oblong hole adjusting head by turning in or out the piston rod such that it acts as the stop damper.

### Bleeding the brake

When the piston of the brake cylinder is loosened and the brake cylinder is pivoted upwards, you can achieve, that the connection from the wheel brake cylinder to the master cylinder and to the reservoir forms a consistently rising line. This allows bleeding the brake system without difficulty in the manner described below.

**Warning:** *Use only brake fluids based on mineral oils (see also Section 2.3.2)!*

*Do not spill any - the fluid is toxic!*

In order to prevent the entry of air, the brake fluid is poured from the bottom upwards. A simple filling rig would require about 2 m (6.6 ft) of instrument hose with a funnel at the top end, filled with about  $\frac{1}{4}$  l (0.066 US Gal.) of brake fluid. A bleeder screw is fitted to the base of the disc brake cylinder. Fit the bottom end of the hose on the bleeder screw, which would then be rotated to open the valve inside.

Hold the funnel as high as practicable to give the brake fluid a head of pressure. It is essential to ensure that the brake fluid is free from bubbles to avoid including air in the system. To ensure this, there must always be enough fluid in the funnel. Continue filling until the reservoir contains about  $\frac{2}{3}$  of capacity.

Then the bleeder screw should be closed tight and the hose removed. Do not forget to replace the dust cap!

Check the brake system for leaks, action and effective brake operation!

For the refilling of brake fluid the small plastic tank is taken out of its support. Open and refill brake fluid!

If the brake system has been emptied already to such an extent that air has penetrated between master cylinder and operating cylinder, filling up must be done again from bottom to top.

### **Minimum thickness of brake linings and brake disc**

The **brake linings** must be replaced if the thickness is down to 2.54 mm / 0.10 in.!

The **brake disc** must be replaced if the thickness is down to 4.242 mm / 0.167 in.!

In order to prevent the entry of air, the brake fluid is poured from the bottom upwards. A simple filling rig would require about 2 m (6.6 ft) of instrument hose with a funnel at the top end, filled with about  $\frac{1}{4}$  l (0.066 US Gal.) of brake fluid. A bleeder screw is fitted to the base of the disc brake cylinder. Fit the bottom end of the hose on the bleeder screw, which would then be rotated to open the valve inside.

Disassemble the reservoir (expansion tank) from its mounting and hold it upright. Open the filler cap and remove the diaphragm.

Hold the funnel as high as practicable to give the brake fluid a head of pressure. It is essential to ensure that the brake fluid is free from bubbles to avoid including air in the system. To ensure this, there must always be enough fluid in the funnel.

Fill the expansion tank nearly to full capacity. Then the bleeder screw should be closed tight and the hose removed. Do not forget to replace the dust cap! Insert the diaphragm in the expansion tank in a way that no air remains underneath it. Collect the waste brake fluid with a wipe. Finally close the filler cap and remount the expansion tank.

Check the brake system for leaks, action and effective brake operation!

For the refilling of brake fluid the small plastic tank is taken out of its support. Open and refill brake fluid!

If the brake system has been emptied already to such an extent that air has penetrated between master cylinder and operating cylinder, filling up must be done again from bottom to top.

### **Minimum thickness of brake linings and brake disc**

The **brake linings** must be replaced if the thickness is down to 2.54 mm / 0.10 in.!

The **brake disc** must be replaced if the thickness is down to 4.242 mm / 0.167 in.!

- Remove the air intake filter [20] and set the throttle to **Wide Open** (so that the throttle valve remains open). An application bottle or a syringe is fixed to a thin Silicone hose which is introduced on a length of 475 mm (1.6 ft) into the intake ram pipe [21]. Then inject 5 ccm (0.17 oz) engine oil through this hose direct into the engine.

**Warning:**

Never rotate the engine when the oil injection hose is still extending into the butterfly valve housing!

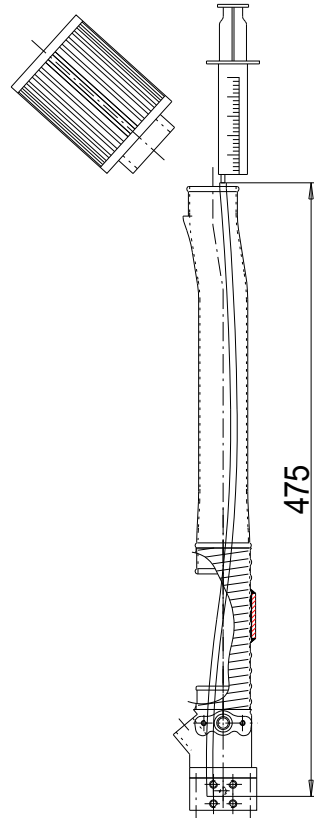

- Pull back the hose and manually rotate the engine through one turn, to be read off at the starter gear rim (this corresponds to about 1/3rd revolution of the propeller).
- Repeat this action five times while injecting each time 5 ccm (0.17 oz) engine oil.

For information: when the starter gear rim has reached one turn, this is only 1/3rd revolution of the rotor. If this action is done altogether six times, it is guaranteed that oil is introduced into all three combustion chambers.

- In order to distribute the oil evenly in all chambers the propeller is rotated several times by hand prior to starting the engine.

**Warning:** *Make sure that all electrical circuits and ignition circuits are **off** so that the propeller can be moved by hand without any risks.*

- Start the engine while observing all safety measures. Distinct formation of smoke for a short time is normal.
- Carry out a full engine ground run according to the instructions in the engine manual and record the results in the respective form contained in the engine manual.

**Warning:** *Operate the engine only with mounted wings or a special console, which ties down the fuselage. Do not make any adjusting works with running power-plant.*

#### 2.11.4 Dismounting and Mounting the Power-Plant

The following two chapters describe how to dismount and mount the power-plant. This may become necessary for maintenance, repair or weight reduction or compliance with competition rules. The only components left in the fuselage are the fuel system and all cockpit engine controls.

*Fig. 3.1-1 Control surface deflections, rigging angles, and jacking points for the wing bending frequency test*

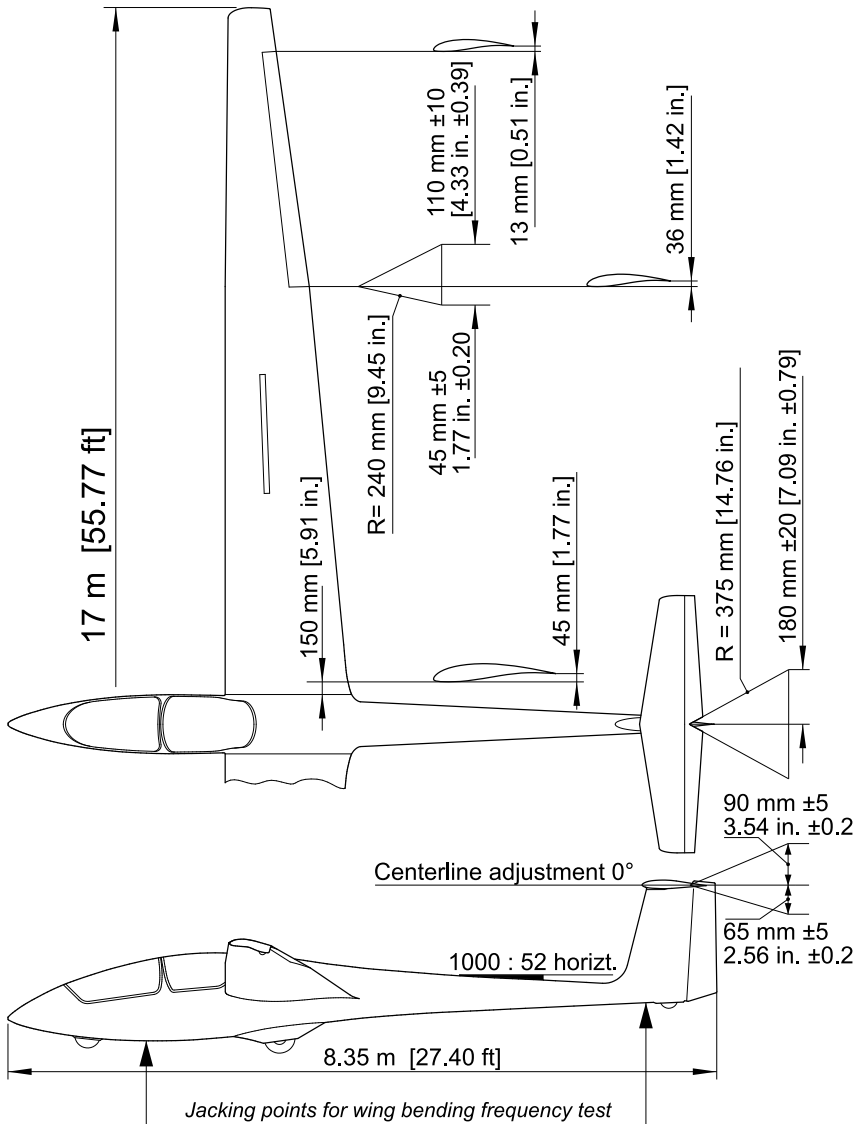

## 6.1 Introduction

This Section describes the procedures for determining the empty mass and the empty mass moment of the aircraft. In addition, procedures for determining the Center of Gravity (C.G.) are provided.

A list of equipment fitted is contained in the most recent and currently valid aircraft inspection report.

As the C.G. position is of vital importance for safe flight, the limits laid down must not be exceeded on no account.

It is especially important after repairs, re-finishing and the fitting of additional equipment to ensure that the empty mass C.G. remains within permissible limits. If this cannot be proved by calculation, the aircraft must be re-weighed.

### Unit Conversions

25.4 mm = 1 in

0.4536 kg = 1 lb

## 6.2 Weighing Procedure

The Datum (Reference) Point (German: **BezugsPunkt = BP**) for weighing and calculating the C.G. is the **wing leading edge** at the root rib.

Prior to weighing, level the aircraft so that the top edge of a wedge 1000 : 52 placed on the tail boom in front of the fin, is horizontal (see Fig. 6.2-1). The weighing is best done on two scales.

## 6.1 Introduction

This Section describes the procedures for determining the empty mass and the empty mass moment of the aircraft. In addition, procedures for determining the Center of Gravity (C.G.) are provided.

A list of equipment fitted is contained in the most recent and currently valid aircraft inspection report.

As the C.G. position is of vital importance for safe flight, the limits laid down must not be exceeded on no account.

It is especially important after repairs, re-finishing and the fitting of additional equipment to ensure that the empty mass C.G. remains within permissible limits. If this cannot be proved by calculation, the aircraft must be re-weighed.

### Unit Conversions

25.4 mm = 1 in

0.4536 kg = 1 lb

## 6.2 Weighing Procedure

The Datum (Reference) Point (German: **BezugsPunkt = BP**) for weighing and calculating the C.G. is the **wing leading edge** at the root rib.

Prior to weighing, level the aircraft so that the top edge of a wedge 1000 : 52 placed on the tail boom in front of the fin, is horizontal (see Fig. 6.2-1). The weighing is best done on two scales.

**CAUTION:** *Only calibrated scales may be used for weighing. The lever arms for determining the empty mass c.g. have to be determined during every new weighing.*

Fig. 6.2-1 Determining Empty Mass C.G.

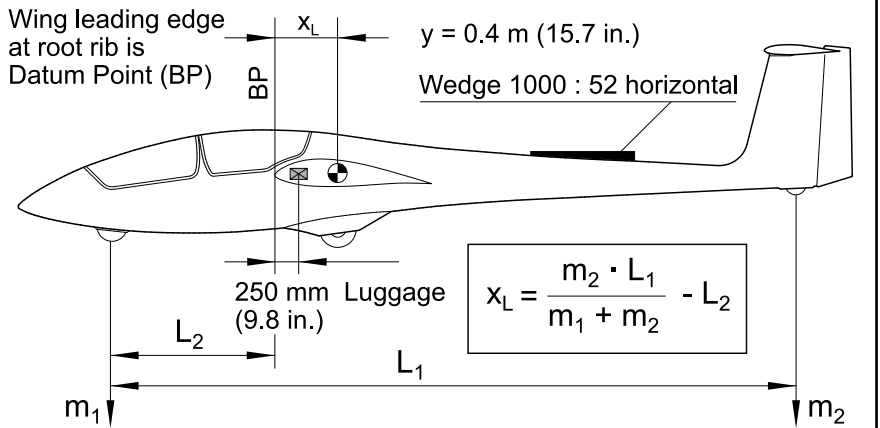
**Empty mass C.G.  $x_L$ :**

$$x_L = \frac{m_2 \cdot L_1}{m_1 + m_2} - L_2$$

**Empty mass  $m_L$ :**

$$m_L = m_1 + m_2$$

The aircraft must be prepared for weighing as follows:

1. flight instruments fitted and canopies closed
2. seat backrests, seat cushions or equivalent in place
3. with aircraft log book and Flight Manual in place
4. without removable trim ballast in the front cockpit, if supplied
5. without parachutes
6. without oxygen bottle (if supplied)

If the aircraft is operated with the engine:

7. engine installed and retracted
8. with unusable fuel

Fig. 6.2-1 Determining Empty Mass C.G.

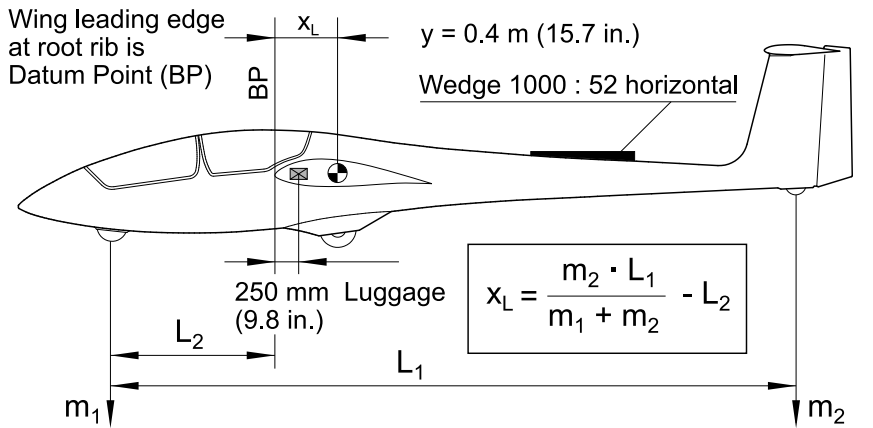
**Empty mass C.G.  $x_L$ :**

$$x_L = \frac{m_2 \cdot L_1}{m_1 + m_2} - L_2$$

**Empty mass  $m_L$ :**

$$m_L = m_1 + m_2$$

The aircraft must be prepared for weighing as follows:

1. flight instruments fitted and canopies closed
2. seat backrests, seat cushions or equivalent in place
3. with aircraft log book and Flight Manual in place
4. **without removable trim ballast** in the front cockpit
5. without parachutes
6. without oxygen bottle (if supplied)

If the aircraft is operated with the engine:

7. engine installed and retracted
8. with unusable fuel

## 9.1 General Placards

The whole of the placards and pictograms is listed and explained in Sections 2 and 7 of the **Flight Manual**.

The consecutive numbers as marked against the placards shown hereafter refer to their location in the aircraft and match the numbers shown in Figs. 9-1 to 9-4 at the end of this Section.

1



Only for US-registered aircraft: Underneath the registration the type certificate number has to be added.

13

Segelflugzeugbau Alexander Schleicher GmbH & Co. Poppenhausen		Serial-No.: <b>21</b>
Model: <b>ASK 21 Mi</b>		
<b>DATA and LOADING PLACARD</b>		
Empty Mass (Weight):	lbs	kg
Max. Mass (Weight):	1554 lbs	705 kg
Min. Front Seat Load Solo:	lbs	kg
Max. Front Seat Load:	lbs	kg
Max. Rear Seat Load:	lbs	kg
Max. Total Combined Seat Load	lbs	kg
<b>Tire Pressure</b>	Main Wheel: 3.4 to 3.6 bar / 49 to 52 psi	
	Nose Wheel: 1.9 to 2.1 bar / 28 to 30 psi	
	Tail Wheel: 2.4 to 2.6 bar / 35 to 38 psi	
<b>Maximum Permissible Speeds with retracted Power-Plant</b>		
Calm Air:	151 kts 280 km/h	
Manoeuvring Speed:	97 kts 180 km/h	
Winch and Autotow Launch:	81 kts 150 km/h	
Aerotow A/T:	97 kts 180 km/h	
<b>with Power-Plant installed</b>		
To extend/retract Propeller:	min. 49 kts 90 km/h	
	max. 65 kts 120 km/h	
Propeller extended:	max. 86 kts 160 km/h	
<b>Weak Link</b>	900 to 1100 daN (black)	
Winch Launch:	max 900 daN (brown)	
Aerotow:		

Segelflugzeugbau Alexander Schleicher GmbH & Co. Poppenhausen

Model: **ASK 21 Mi**

Serial-No.: **21**

**DATA and LOADING PLACARD**

Empty Mass (Weight): 

lbs	kg
-----	----

  
 Max. Mass (Weight): 

1554 lbs	705 kg
----------	--------

  
 Min. Front Seat Load Solo: 

lbs	kg
-----	----

  
 Max. Front Seat Load: 

lbs	kg
-----	----

  
 Max. Rear Seat Load: 

lbs	kg
-----	----

  
 Max. Total Combined Seat Load: 

lbs	kg
-----	----

**Tire Pressure** Main Wheel: 

3.4 to 3.6 bar / 49 to 52 psi
-------------------------------

  
 Nose Wheel: 

1.9 to 2.1 bar / 28 to 30 psi
-------------------------------

  
 Tail Wheel: 

2.4 to 2.6 bar / 35 to 38 psi
-------------------------------

**Maximum Permissible Speeds with retracted Power-Plant**

Calm Air: 

151 kts	280 km/h
97 kts	180 km/h
81 kts	150 km/h
97 kts	180 km/h

  
 Maneuvering Speed:   
 Winch and Autotow Launch:   
 Aerotow A/T:

**with Power-Plant installed**

To extend/retract Propeller: 

min. 49 kts	90 km/h
max. 65 kts	120 km/h

  
 Propeller extended: 

max. 86 kts	160 km/h
-------------	----------

**Weak Link**

Winch Launch: 

900 to 1100 daN (black)
-------------------------

  
 Aerotow: 

max 900 daN (brown)
---------------------

14

## Pre Flight Check

1. Check main pins (secured)
2. Check control connections  
(Quick-release connectors must be secured)
3. Check cockpit and control runs for loose objects
4. Check and test tow release hooks
5. Check controls (positive connections, freedom of movement and play)
6. Check tire pressure and wheel brake
7. Check pitot tube in the nose
8. Check fuselage, wing and tail for damage
9. Check rear wing attachment pins (locked)
10. Check static pressure openings
11. Check TE probe
12. Check elevator and rudder
13. Check mass and balance
14. Check fuel contents
15. Check engine as per the manual

15

## Pre Take-off Check:

1. Remove tail dolly
2. Fasten parachute
3. If applicable connect rip-chord for automatic parachute
4. Take a correct seat position
5. Fasten seat harness  
(especially tighten lap straps)
6. Check free movement of the controls
7. Close airbrakes and lock them
8. Check spin ballast (optional)
9. Set trim in take-off position
10. Set altimeter
11. Check radio transmission
12. Check wind direction
13. Recap the take-off interruption procedure
14. Close and lock canopy

16



Prior to take-off check  
weight of the trim plates  
and their secure fixing

One 3 kg (6.61 lbs) trim plate  
beside the nose tow release equals  
a front pilot mass of 3.75 kg (8.26 lbs)

14

**Pre Flight Check**

1. Check main pins (secured)
2. Check control connections  
(Quick-release connectors must be secured)
3. Check cockpit and control runs for loose objects
4. Check and test tow release hooks
5. Check controls (positive connections, freedom of movement and play)
6. Check tire pressure and wheel brake
7. Check pitot tube in the nose
8. Check fuselage, wing and tail for damage
9. Check rear wing attachment pins (locked)
10. Check static pressure openings
11. Check TE probe
12. Check elevator and rudder
13. Check mass and balance
14. Check fuel contents
15. Check engine as per the manual

15

**Pre Take-off Check:**

1. Remove tail dolly
2. Fasten parachute
3. If applicable connect rip-chord for automatic parachute
4. Take a correct seat position
5. Fasten seat harness  
(especially tighten lap straps)
6. Check free movement of the controls
7. Close airbrakes and lock them
8. Check spin ballast (optional)
9. Set trim in take-off position
10. Set altimeter
11. Check radio transmission
12. Check wind direction
13. Recap the take-off interruption procedure
14. Close and lock canopy

17

**Approved Aerobic Manoeuvres**

Aerobatics are only approved with retracted engine

only without spin ballast:

- Looping (positive)
- Lazy Eight
- Steep Turn

with or without spin ballast:

- Spin

18

V <sub>NE</sub> Speed Limit for high Altitude		V <sub>NE</sub> Speed Limit for high Altitude		V <sub>NE</sub> Speed Limit for high Altitude	
Altitude msl (m)	V <sub>max</sub> IAS [km/h]	Altitude msl (ft)	V <sub>max</sub> IAS [kts]	Altitude msl (ft)	V <sub>max</sub> IAS [kts]
0 - 2000	280	0 - 6500	151	0 - 6500	174
< 3000	267	< 8000	147	< 8000	170
< 4000	255	< 12000	139	< 12000	160
< 5000	239	< 16000	130	< 16000	150
< 6000	226	< 20000	121	< 20000	140

19

Baggage compartment **max. 10 kg**  
**22 lbs**

20

Deviation-Table			
for	steer	for	steer
0		180	
30		210	
60		240	
90		270	
120		300	
150		330	
Date:			

16

 Prior to take-off, check weight of the trim plates and their secure fixing

---

**1 Plate (3kg; 6.6lbs) beside the nose tow release equals a front pilot mass of 3.75 kg (8.26 lbs)**

---

**1 Plate (1kg; 2.2lbs) in front of the pedals equals a front pilot mass of 1.7 kg (3.74 lbs)**

17

**Approved Aerobic Manoeuvres**

Aerobatics are only approved with retracted engine

---

only without spin ballast:  
 Looping (positive)  
 Lazy Eight  
 Steep Turn

---

with or without spin ballast:  
 Spin

18

V <sub>NE</sub> Speed Limit for high Altitude		V <sub>NE</sub> Speed Limit for high Altitude		V <sub>NE</sub> Speed Limit for high Altitude	
Altitude msl [m]	V <sub>max</sub> IAS [km/h]	Altitude msl [ft]	V <sub>max</sub> IAS [kts]	Altitude msl [ft]	V <sub>max</sub> IAS [mph]
0 - 2000	280	0 - 6500	151	0 - 6500	174
< 3000	267	< 8000	147	< 8000	170
< 4000	255	< 12000	139	< 12000	160
< 5000	239	< 16000	130	< 16000	150
< 6000	226	< 20000	121	< 20000	140

19

Baggage compartment **max. 10 kg 22 lbs**

20

Deviation-Table			
for	steer	for	steer
0		180	
30		210	
60		240	
90		270	
120		300	
150		330	
Date:			

35

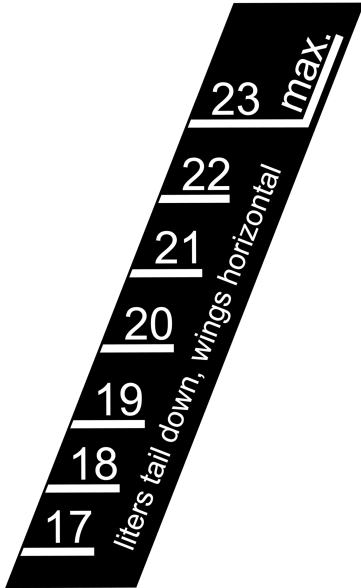

36

Engine-Oil:   
Silkolene Comp 2  
Pre-mix  
Castrol Aviation A545 or  
Bardahl KGR Injection Oil  
or Spectro Oils of America  
"Golden Spectro"  
**Top up with each  
refuelling !**

If the aircraft has not installed the minimum equipment for cloud flying (see aircraft flight manual section 2.13), this placard is located near the data placard:

**Cloud flying is not permitted!**

If the aircraft has installed the minimum equipment for cloud flying (see aircraft flight manual section 2.13), this placard is located near the data placard:

**Cloud flying permitted  
as per flight manual**

## 10.4 Dismounting and Mounting Tow Release Hook Couplings

The tow release hook couplings are accessible after removing the covering panels in the cockpit.

After undoing the mounting bolts the nose tow release coupling can be pulled outside, while the center of gravity (CG) tow release hook coupling can be taken out upwards.

When mounting tow release couplings, use bolts of strength grade 10.9 or 12.9 again, as well as nuts of strength grade 6. If replacement of a tow release coupling is required, also replace bolts and nuts with new ones.

Torque moment for the mounting bolts of the tow release hook couplings: 8.75Nm (6.45 ft·lb).

Where in doubt, the "Operating Manual for tow release hook couplings", issued by the manufacturer Tost, is applicable.

The correct installation of the Bowden cable at the front tow release hook coupling is shown in the picture below:

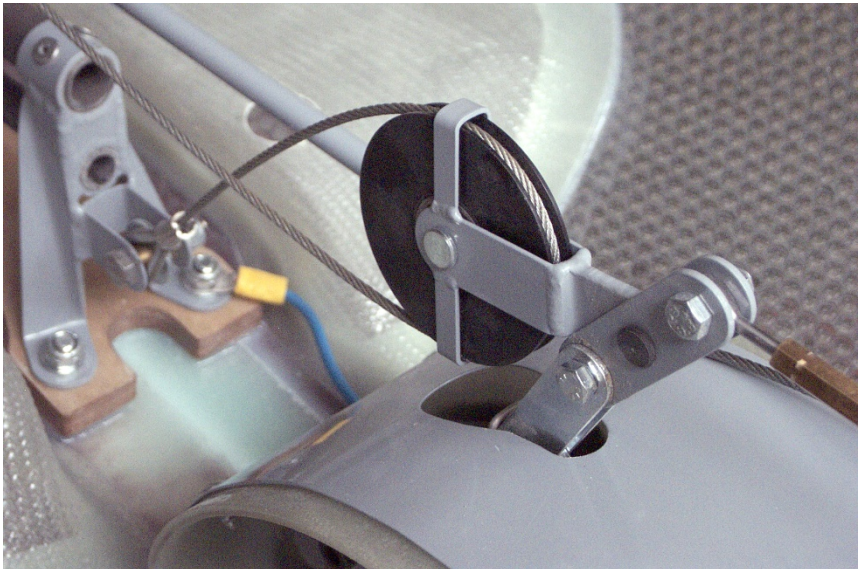

The turnbuckle at the nose tow release coupling must be adjusted such that both couplings release at about the same time. Both tow release couplings must be actuated until they are entirely opened. In the closed condition none of the Bowden cables must be under tension.

## 10.5 Dismounting and Mounting of Power-Plant Components

See Section 2.11.4

## 10.6 Tightening Torque Moments

### Table of maximum permissible torques for bolts in standard bolted connections.

These data also apply to the bolted connections at the power-plant unit, but **NEITHER** to the engine IAE 50R-AA itself, **NOR** to the groove nuts at the propeller shaft and engine drive shaft, **NOR** to the radial screws at the Centaflex rubber coupling at the belt drive, **NOR** to the six screws at the propeller!

Thread size	Nm	ft·lb
M4	1.8	1.3
M5	3.6	2.7
M6	6.4	4.7
M8	16.0	12.0
M10	32.0	23.5
M12	57.0	42.0
M14	92.0	68.0

Torque moments of the groove nuts at **propeller shaft** and **engine drive shaft**:

Thread size	Nm	ft·lb
M24 x 1.5 Propeller shaft	150	110
M38 x 1.0 Propeller shaft	120	88
M30 x 1.5 Engine drive shaft	120	88
M20 x 1.5 Engine crank shaft	120	88

Torque moments of the radial bolts at the **Centaflex rubber coupling** at the belt drive:

Thread size	Nm	ft·lb
M10	50	37

Torque moments of the **Fittings** at the Teflon fuel hoses (e.g. at the separation junctions for power-plant dismounting and mounting)

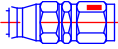
	Dimension across Flats (A/F) [Inch]	Dimension across Flats (A/F) metric [mm]	Fitting, made of	Torque Moment [Nm]	Torque Moment ft·lb
	A/F 9/16"	14.28	Steel	18 - 20	13.3 - 14.8
	A/F 11/16"	17.50	Aluminium	15 - 18	11 - 13.3
		A/F 19	Aluminium	15 - 18	11 - 13.3

Torque moments of the **engine IAE R50-AA**:

see Engine Manual

Torque moments of the **propeller**:

see Operating and Maintenance Instructions for the propeller AS2F1 in Section 7.

## Minimum Equipment:

See **Flight Manual** Sections 2.10 and 2.13

Manufacturer	Type	Data Sheet Spec. No.	Measuring Range	Ref. No.
--------------	------	----------------------	-----------------	----------

**Airspeed Indicator**

Winter	6 FMS 421	TS 10.210/15	40-300km/h	AS-4-21Mi
	6 FMS 441	TS 10.210/15	40-350km/h	AS-4-21Mi
	6 FMS 521	TS 10.210/16	50-350km/h	AS-4-21Mi
	7 FMS 421	TS 10.210/19	40-300km/h	AS-4-21Mi
	7 FMS 422	TS 10.210/19	0-180mph	AS-5-21Mi
	7 FMS 423	TS 10.210/19	0-160kts	AS-6-21Mi
	7 FMS 511	TS 10.210/20	50-300km/h	AS-4-21Mi
PZL	PRM-035	-	20-350km/h	-
	PR-350-A	-	0-350km/h	-
	PS 08	-	50-300km/h	-
Badin		-	50-350km/h	-

**Altimeter**

Winter	4 HM 6	TS 10.220/44	0-6000 m	-
	4 FGH 10	TS 10.220/46	0-10000 m	-
	4 FGH 20	TS 10.220/47	0-10000 m	-
	4 FGH 20	TS 10.220/47	0-30000 ft	-
PZL	PW-12-C/A/X	-	0-6/10/12 km	-
	WD-10	-	0-10000 m	-
	W-12S-A	-	0-12000 m	-
Jaeger		212	0-10000 m	-

**Four-Part Safety Harness**

Gadringer	Type ASK 21	40.070/32 40.071/05	-	-
Schroth	front: 4-02-1902xx rear: 4-02-1802xx	40.073/11	-	-

## 13.4 Maintenance Instructions

The following Maintenance Instructions are established from time to time as required, in accordance with experience accumulated in operating the ASK 21 Mi. The Maintenance Manual is to be supplemented in case of new issues of Maintenance Instructions.

**"PAINT CRACKS"** dated June 26, 1989, (general Maintenance Instruction) describes how to inspect, preserve, and repair the paint surface.

**"ALL FRP GLIDER MODELS"** dated June 19, 1986, (general Maintenance Instruction) describes the removing of play between the sockets (= bushings) and bolts (= pins) of the wing-to-fuselage connection.

**Maintenance Instruction A** of the ASK 21, dated March 23, 1987 describes the adjustment of the airbrake locking.

**Maintenance Instruction B** of the ASK 21 (issue III, January 7, 2021) describes the installation of oversize drag-pins at the wing-fuselage junction.

**Maintenance Instruction C** of the ASK 21 (issue 2, December 1, 2007) describes the attachment of the plastic fairing tape (elastic lip seal) at the control surface gaps of aileron and horizontal and vertical tail.

**Maintenance Instruction A** of the ASK 21 Mi (issue 1, December 1, 2007) describes the attachment of the plastic fairing tape (elastic lip seal) on the engine bay doors.

**Maintenance Instruction „Adjusting the drive belt“**, dated August 27, 2007, describes the adjustment of the drive belt tension and its running position.

**Maintenance Instruction „To vent the oil pump“**, dated March 25, 1997, describes how to get the oil pump free from enclosed air.

**Maintenance Instruction „Fuel types“** Issue II, dated November 1, 2001, describes the use of car fuel grades.

### 3. Weighing and Spin Ballast Table

With every new weighing of the aircraft, any spin ballast-table (Flight Manual page 9.A.8 respectively 9.B.12) must be removed. Removing the spin ballast-table does not compromise airworthiness of the ASK 21 Mi. But spin ballast may not be used without valid spin ballast-table.

A new table for the spin weights can be requested from the manufacturer. For this purpose a copy of the weighing report and of the equipment list, signed and stamped by the inspector, must be forwarded to SCHLEICHER. The new table must be filed into the Flight Manual behind the page 9.A.7.

If the weighing was done with removed power-plant, this must be distinctly specified when ordering the new spin ballast table. In that case the new spin ballast table must be inserted behind page 9.B.11 and is only applicable for flights with removed power-plant.

### 4. Placards and Markings

An indicating label at the front instrument panel draws the attention to the fitted spin ballast:



A M8-screw must be mounted through the placard from the backside of the instrument panel. When the spin ballast is fitted at the fin (= DANGER), the placard is visible. When the spin ballast is removed, the placard must be covered using the nut and washer that otherwise hold the spin ballast.

The following placard replaces the respective placard (no.15) as shown in Section 9 (in both seats):

### **Pre Take-off Check:**

1. Remove tail dolly
2. Fasten parachute
3. If applicable connect rip-chord for automatic parachute
4. Take a correct seat position
5. Fasten seat harness  
(especially tighten lap straps)
6. Check free movement of the controls
7. Close airbrakes and lock them
8. Check spin ballast (optional)
9. Set trim in take-off position
10. Set altimeter
11. Check radio transmission
12. Check wind direction
13. Recap the take-off interruption procedure
14. Close and lock canopy

Segelfluggzeugbau Alexander Schleicher GmbH & Co. Poppenhausen

Model: **ASK 21 Mi, with engine removed**

Serial-No.: **21**

**DATA and LOADING PLACARD**

Empty Mass (Weight):  lbs  kg  
 Max. Mass (Weight): 1320 lbs 600 kg  
 Min. Front Seat Load Solo:  lbs  kg  
 Max. Front Seat Load:  lbs  kg  
 Max. Rear Seat Load:  lbs  kg  
 Max. Total Combined Seat Load:  lbs  kg

**Tire Pressure** Main Wheel:  3.4 to 3.6 bar / 49 to 52 psi  
 Nose Wheel:  1.9 to 2.1 bar / 28 to 30 psi  
 Tail Wheel:  2.4 to 2.6 bar / 35 to 38 psi

**Maximum Permissible Speeds**

Calm Air:  151 kts 280 km/h  
 Manoeuvring Speed:  97 kts 180 km/h  
 Winch and Autotow Launch:  81 kts 150 km/h  
 Aerotow A/T:  97 kts 180 km/h

**Weak Link**

Winch Launch:  900 to 1100 daN (black)  
 Aerotow:  max 900 daN (brown)

**Permissible Load factor *only with engine removed***

positive:  6.5 g  
 negative:  - 4.0 g

**13.B.6 Engine Removed**